



STARMAX

Assembly instruction

2025-04-01

P1191

Standard: PN-EN 1176-1:2017-12

Size: 6,80 x 4,32 m

Safety zone dimensions: 10,48 x 7,43 m

Safety zone: 54,02 m²

Height: 3,95 m

HIC: 2,00 m

Age: 3+





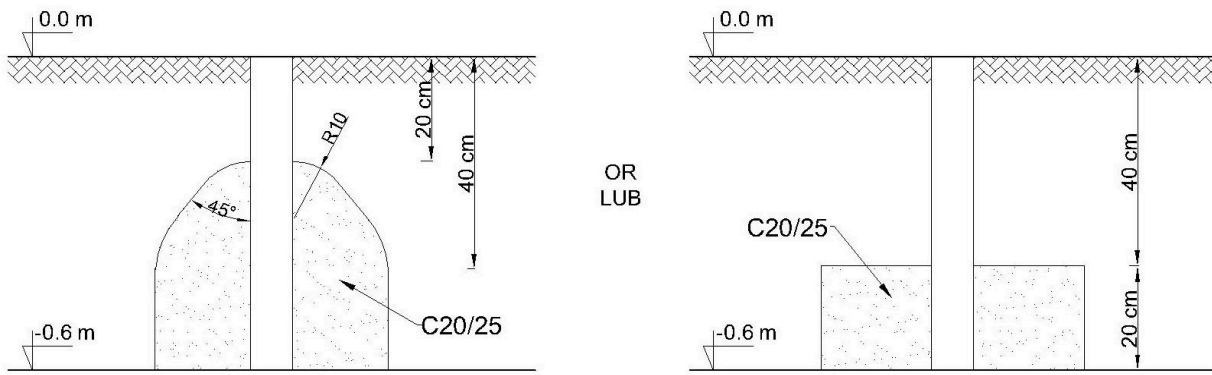



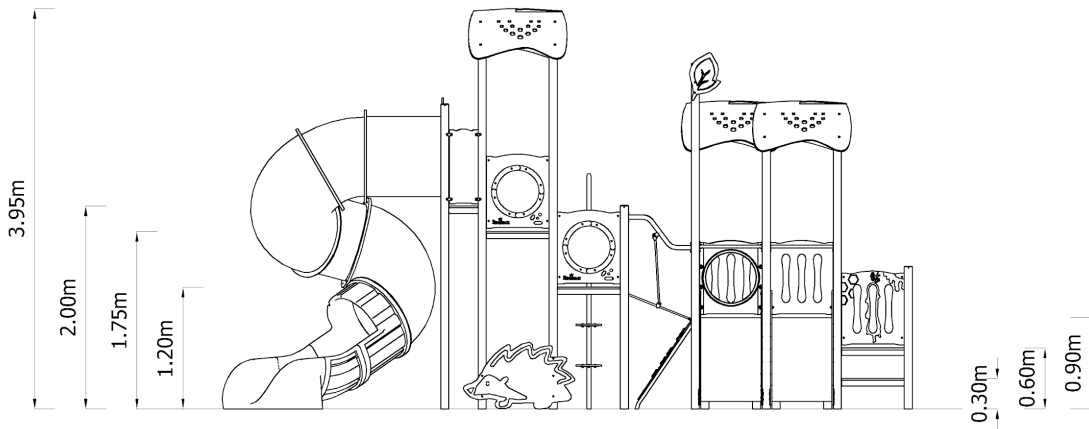

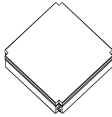
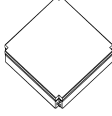

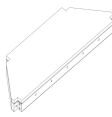
Foundation

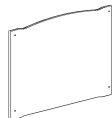
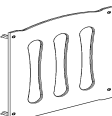
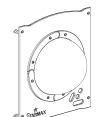

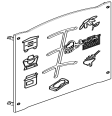



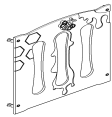
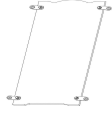
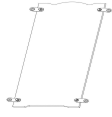
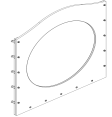

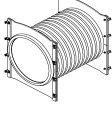
Side view

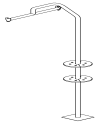





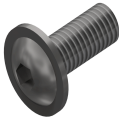



| Module | Name | Picture | Quantity |
|--------|-------------------------------------|---|----------|
| M1101 | Square platform - without fasteners |  | 2 |
| M1102 | Square platform - 1 fastener |  | 3 |
| M1103 | Square platform - 2 fasteners |  | 1 |
| M1111 | Triangular platform |  | 2 |
| M1117 | Trapeze platform for slide |  | 1 |
| M1208 | Slide 90 double |  | 1 |
| M1209 | Tube slide spiral 200 complete |  | 1 |
| M1301 | Full protection |  | 1 |
| M1302 | Perforated Security |  | 4 |
| M1304 | Porthole Security |  | 2 |

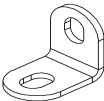





| | | | |
|------------------|--|---|-----------|
| M1334 | Security Beekeeper |  | 1 |
| M1338 | Cover - Rod |  | 10 |
| M1343 | Taper - Handle |  | 3 |
| M1374 | Taper - Handle 618 |  | 1 |
| M1381 | Security Beekeeper |  | 1 |
| M13101 | Full Security on the trapezoidal platform to the slide - full |  | 1 |
| M13101_OL | Full Security on the trapezoidal platform to the slide - full |  | 1 |
| M13102 | Slide entrance Tube 75- full |  | 1 |
| M1418 | Rope crossing 700+30 - full |  | 1 |
| M1427 | Tunnel 700 |  | 1 |

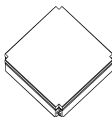

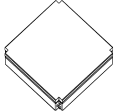
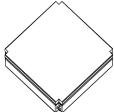

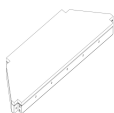
| | | | |
|--------------------|--------------------------------------|---|----------|
| M1514 | Climbing wall 90 |  | 1 |
| M1546 | Fireman's pole with steps 120 |  | 1 |
| M1601 | Wave roof with holes |  | 3 |
| M1710 | Tree house leaf |  | 1 |
| M1711 | Hedgehog |  | 1 |
| P1191-01-22 | Posts P1191 |  | 1 |

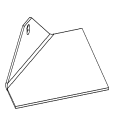

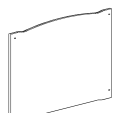
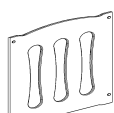
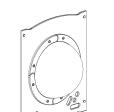

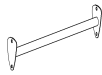

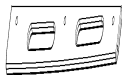
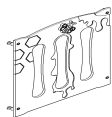
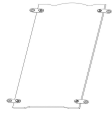
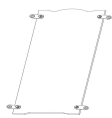
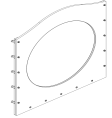

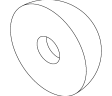

| Module | Name | Picture | Quantity |
|---------------------------|--|---|-----------------|
| ISO7380-2-M8x16-A2 | M8x16 screw with washer head A2 |  | 273 |
| ISO7089-M8-A2 | Round flat washer M8 A2 |  | 95 |
| ISO7380-2-M8x20-A2 | M8x20 screw with washer head A2 |  | 12 |

| | | | |
|--------------------|------------------------------------|---|----|
| DIN986-M8-A2 | Cap nut M8 A2 |  | 76 |
| ISO7380-2-M8x30-A2 | M8x30 screw with washer head A2 |  | 22 |
| B-P0000-07 | Panel mounting angle |  | 76 |
| ISO7380-2-M8x25-A2 | M8x25 screw with washer head A2 |  | 78 |
| DIN986-M10-A2 | Cap nut M10 A2 |  | 4 |
| ISO7089-M10-A2 | M10 A2 washer |  | 4 |
| DIN 986 - M8 | Cap nut M8 A2 |  | 16 |
| ISO7380-2-M8x35-A2 | M8x35 screw with washer head A2 |  | 5 |

| Podzespół | Name | Picture | Quantity |
|-----------|--|---|----------|
| M1101-01 | Square platform - without fasteners |  | 2 |

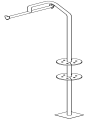
| | | | |
|------------|-----------------------------------|---|----|
| M1102-01 | Square platform - 1 fastener |  | 3 |
| M1103-01 | Square platform - 2 fasteners |  | 1 |
| M1111-01 | Triangular platform twisted |  | 2 |
| M1117-01 | Trapezoidal platform for slide |  | 1 |
| M1208-01 | Slide 90 fixed |  | 1 |
| B-M1001-01 | Column anchor plate 80x80 |  | 24 |
| M1209_01 | Tube slide spiral 200 |  | 1 |
| H-M1301-01 | Full Security - Panel |  | 1 |
| H-M1302-01 | Perforated Security |  | 4 |
| M1304-01 | Porthole Security - Pannel |  | 2 |

| | | | |
|--------------|---|---|----|
| M1334-01 | Security Beekeeper |  | 1 |
| M1338-01 | Rod |  | 10 |
| H-M1343-01 | Zwężka - Uchwyt |  | 6 |
| H-M1374-01 | Taper - Handle 618 |  | 2 |
| M1381-01 | Security bee twisted |  | 1 |
| M13101_01 | Full Security on the trapezoidal platform to slide |  | 1 |
| M13101_01_OL | Full Security on the trapezoidal platform to slide OL |  | 1 |
| M13102_01 | Slide entrance tube 75 |  | 1 |
| M1418_01 | Przejście linowe 700+30 |  | 1 |
| K02 | Screw cap 12 mm |  | 4 |

| | | | |
|------------|-------------------------------------|---|---|
| H-M1428-01 | Distance list tunnel- left |  | 2 |
| H-M1428-02 | Distance list tunnel- right |  | 2 |
| H-M1428-03 | Fixed Tunnel Panel |  | 2 |
| H-M1428-04 | Sliding Panel Tunnel |  | 2 |
| P0803 | Tube 700 |  | 1 |
| M1514-01 | Climbing wall 90 fixed |  | 1 |
| M1546-01 | Fireman's pole with steps 120-fixed |  | 1 |
| M1601-01 | Wave roof with holes - fixed |  | 3 |
| H-M1710-01 | Tree house leaf |  | 1 |
| H-P1500-22 | Hedgehog |  | 1 |

| | | | |
|--------------------|------------------------|---|-----------|
| P1191-01-22 | Posts P1191 |  | 22 |
|--------------------|------------------------|---|-----------|

Assembly order

Step 1 - holes should be dug for the poles
(dimensions and depth on page 2)

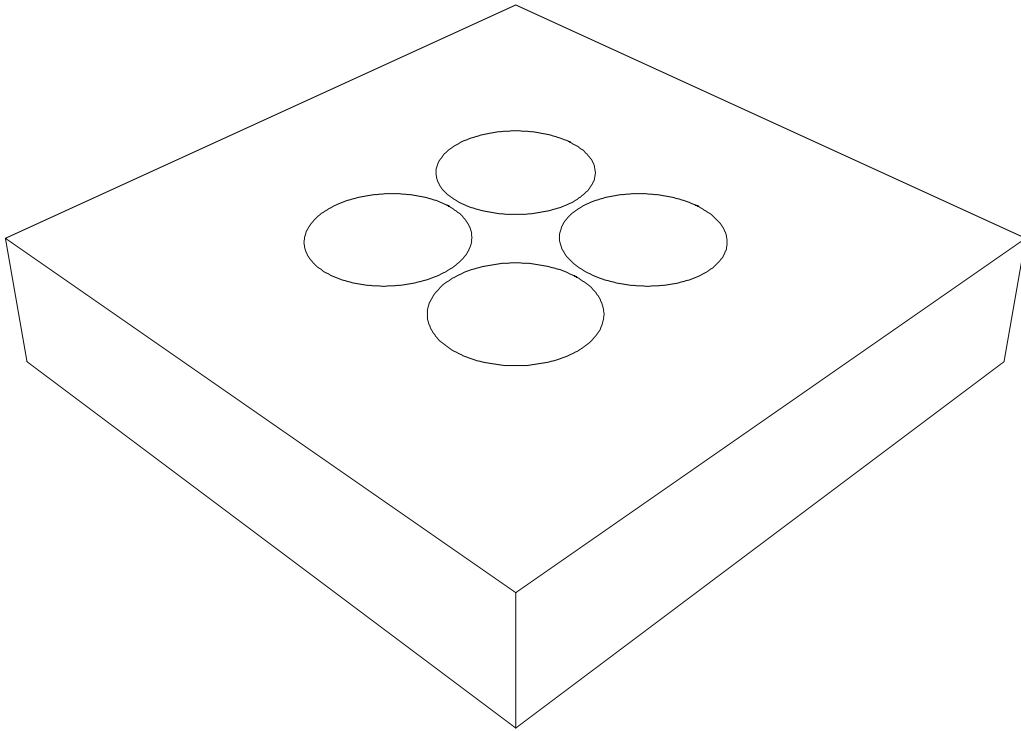

Step 2 - Screw the columns of the set
with the platform and place it in the previously dug holes.

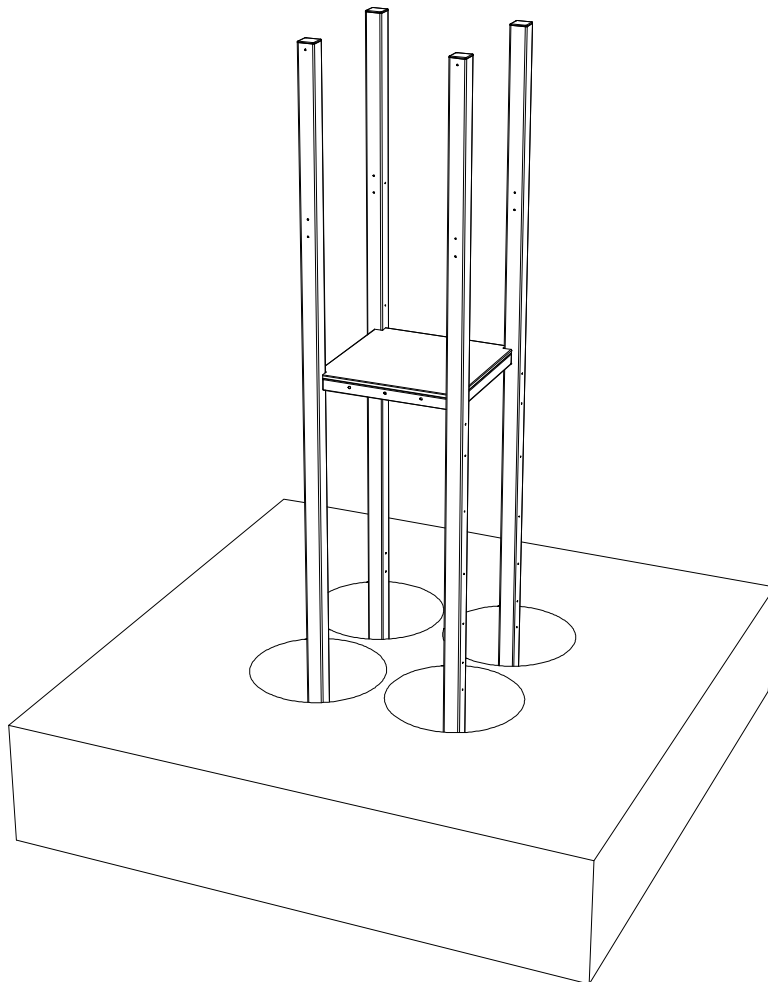

Step 3 - Pre-assemble all components of the set.

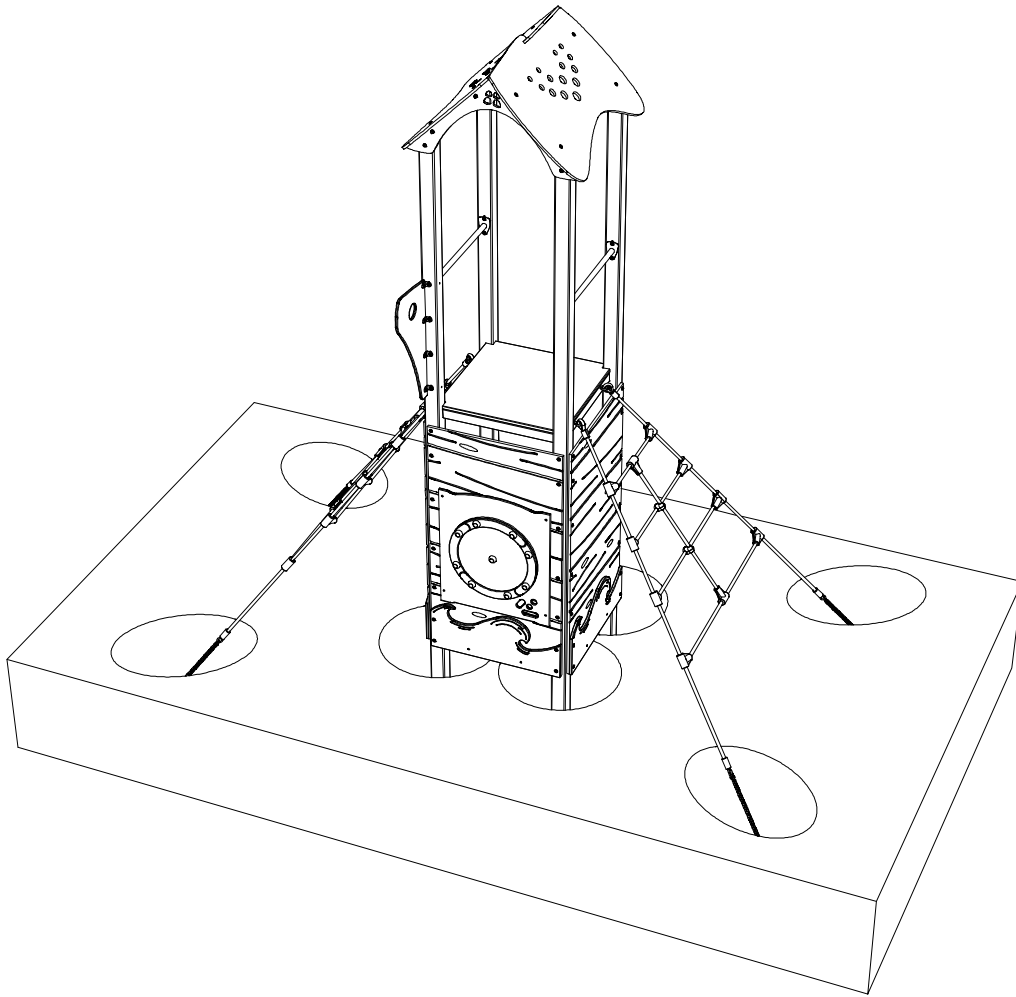

Step 4 - Fill the trenches with concrete according to the specifications on page 2

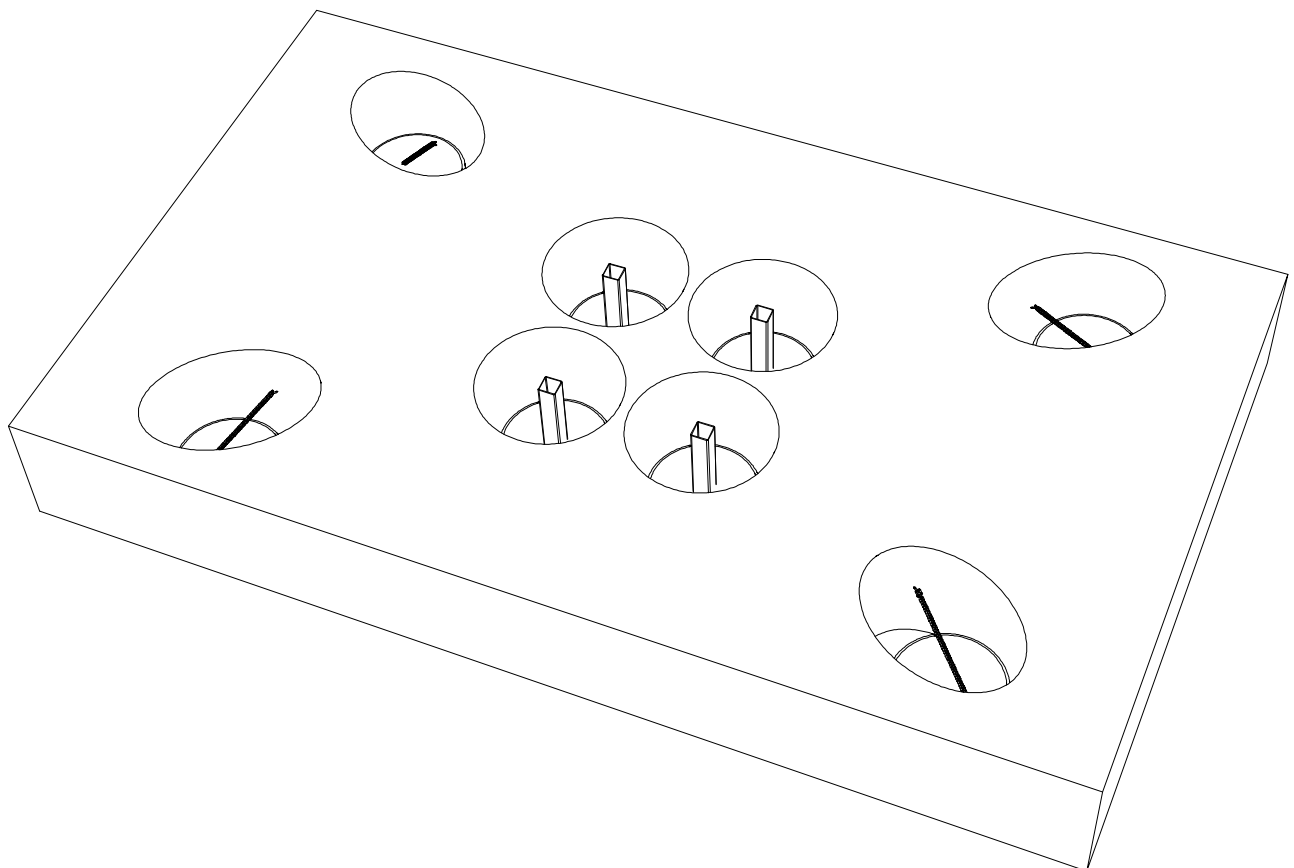

Step 5 - After waiting for the concrete to dry, tighten all the components of the set and backfill the excavations. Prepare the appropriate surface in accordance with the design.

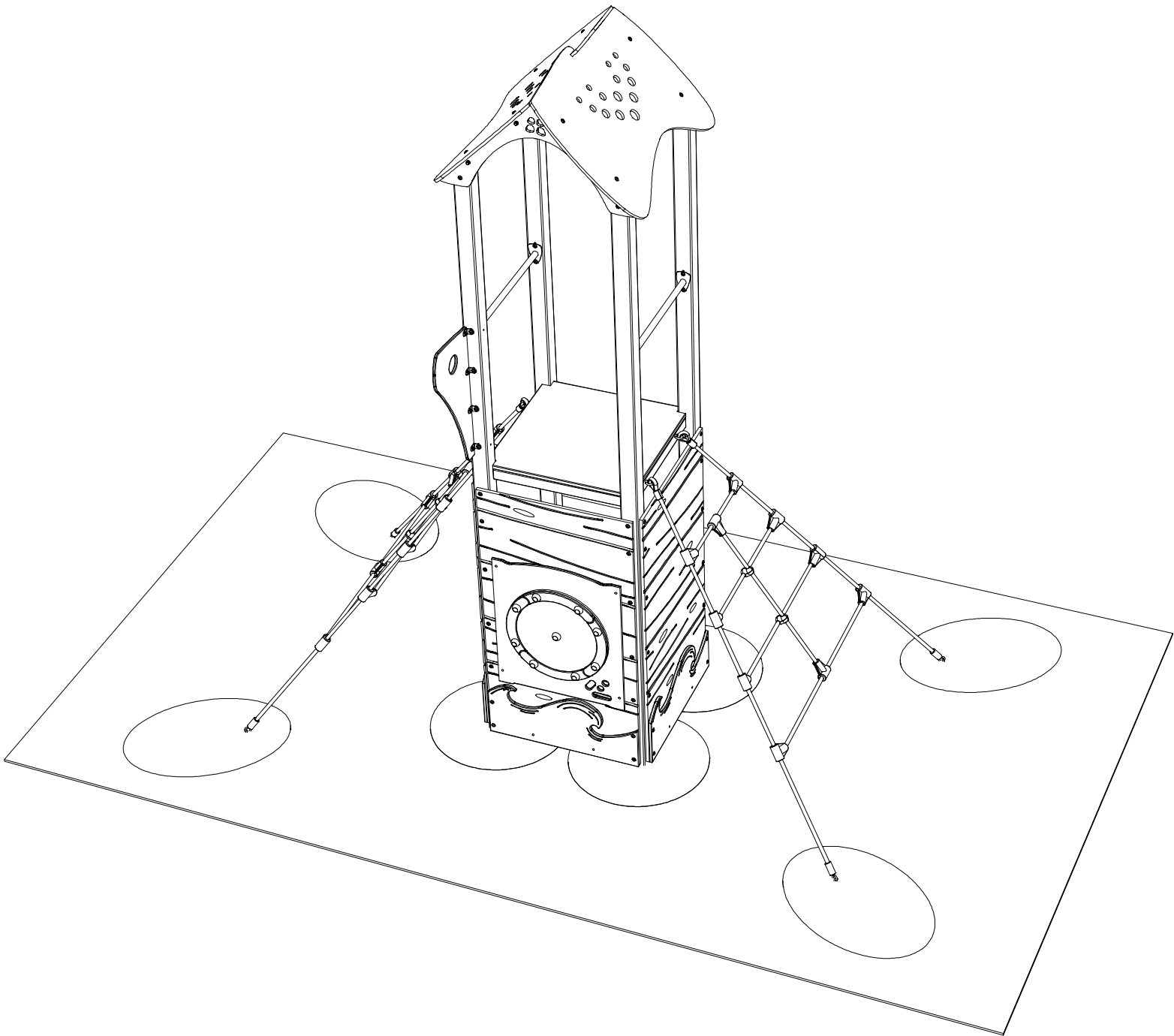

Na czerwono zaznaczono miejsca otworów mocujących w podeście /
In red is the placement of platform's mounting slots

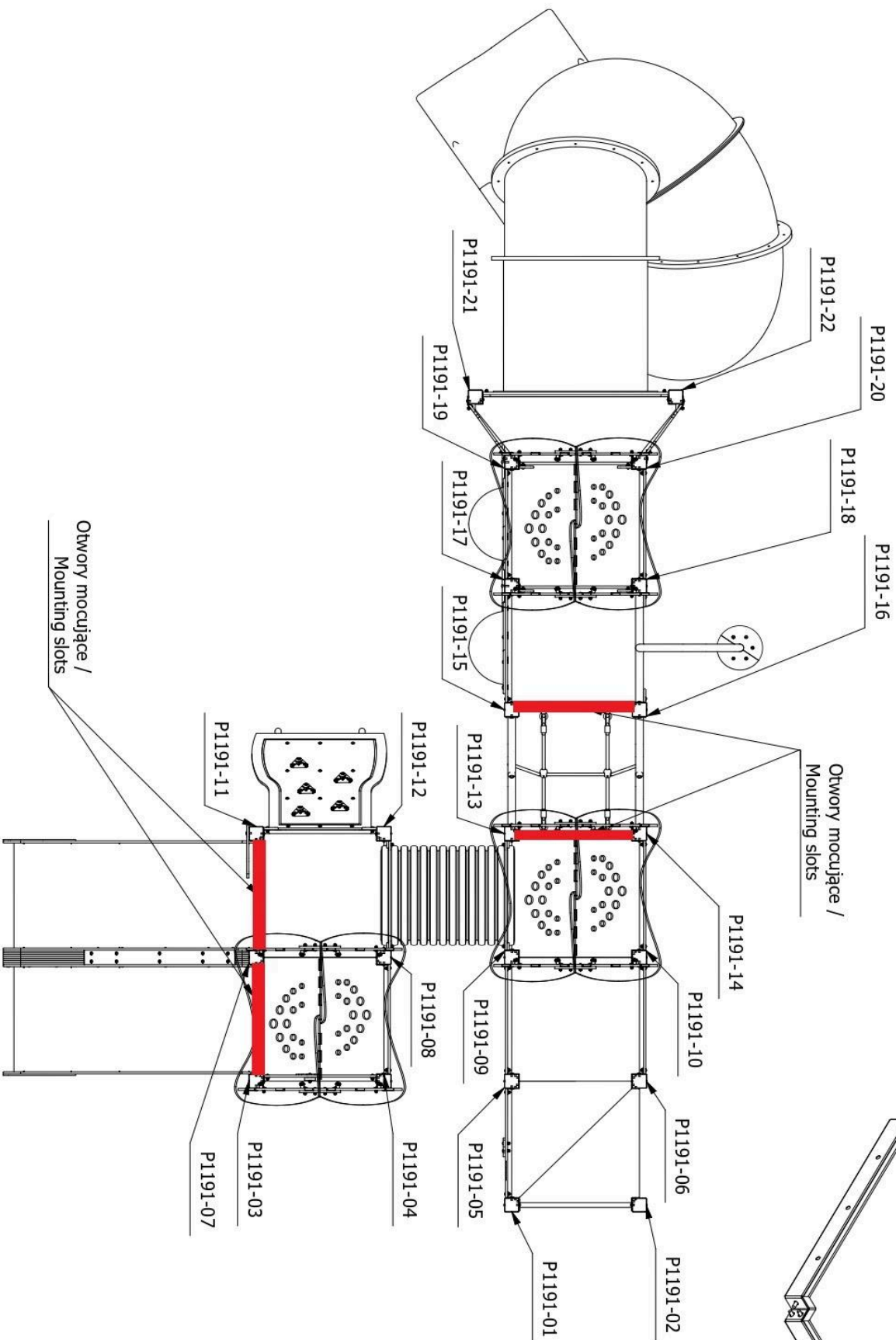

Otwory mocujące /
Mounting slots

Otwory mocujące /
Mounting slots

| Lp./No. | Nr kat. / Cat No | Ilość / Quantity |
|---------|------------------|---------------------|
| 1 | M1101 | 2 |
| 2 | M1102 | 3 |
| 3 | M1103 | 1 |
| 4 | M1111 | 2 |
| 5 | M1117 | 1 |
| 6 | M1208 | 1 |
| 7 | M1209 | 1 |
| 8 | M1301 | 1 |
| 9 | M1302 | 4 |
| 10 | M1304 | 2 |
| 11 | M1334 | 1 |
| 12 | M1338 | 10 |
| 13 | M1343 | 3 |
| 14 | M1374 | 1 |
| 15 | M1381 | 1 |
| 16 | M1418 | 1 |
| 17 | M1427 | 1 |
| 18 | M1514 | 1 |
| 19 | M1546 | 1 |
| 20 | M1601 | 3 |
| 21 | M1710 | 1 |
| 22 | M1711 | 1 |
| 23 | M13101 | 1 |
| 24 | M13101_OL | 1 |
| 25 | M13102 | 1 |
| 26 | P1191-01-22 | 1 |

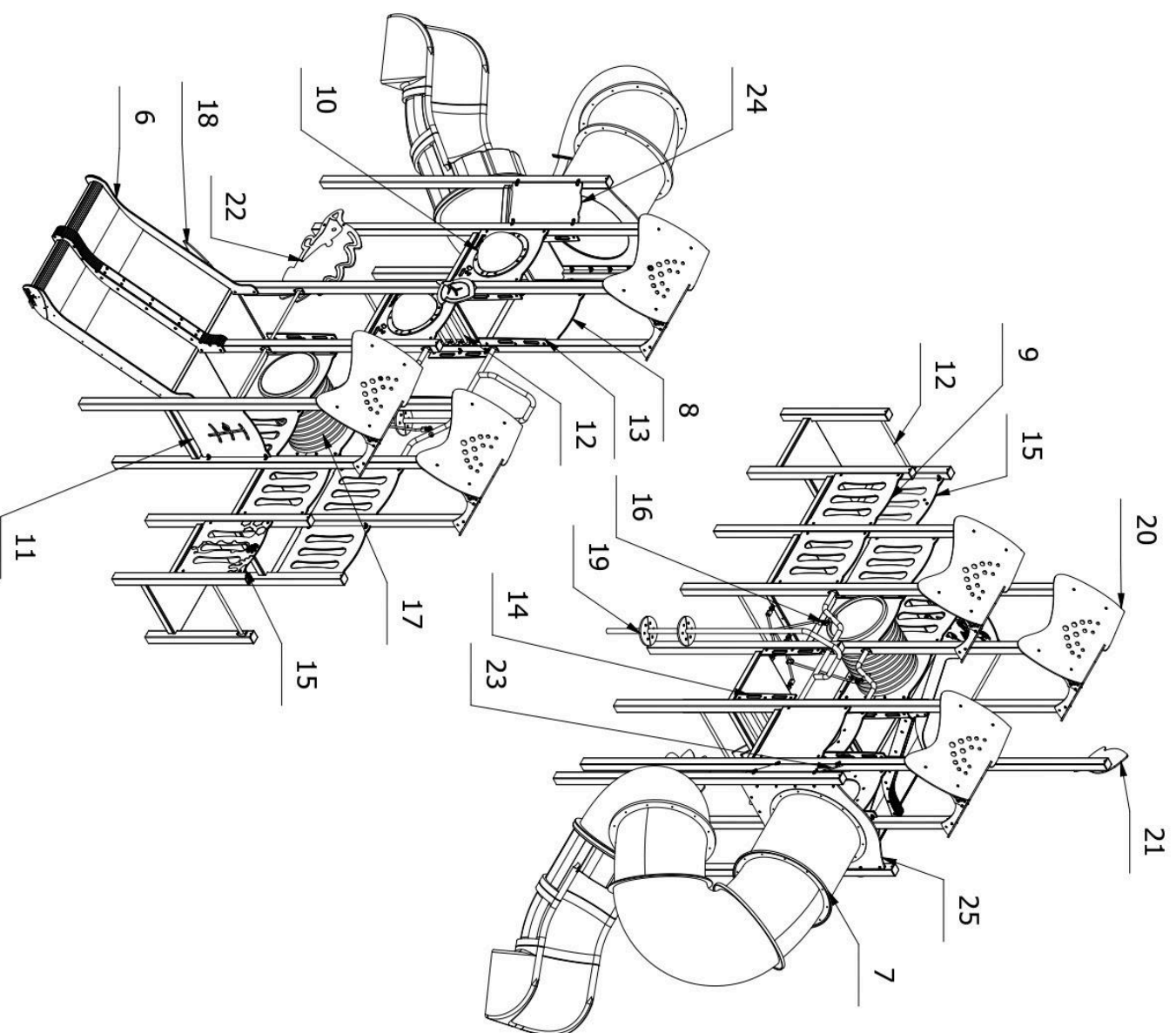

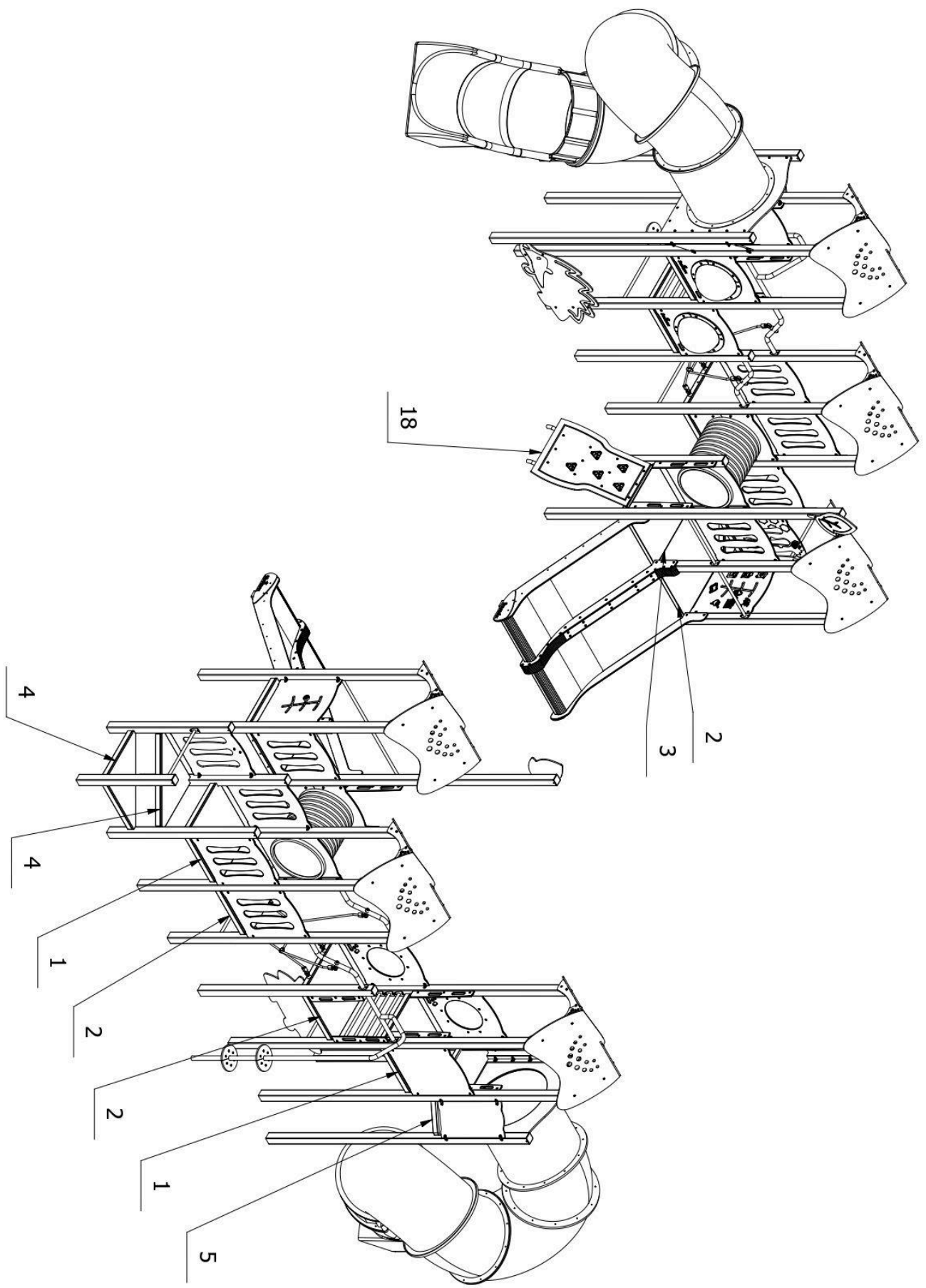

P11**/*

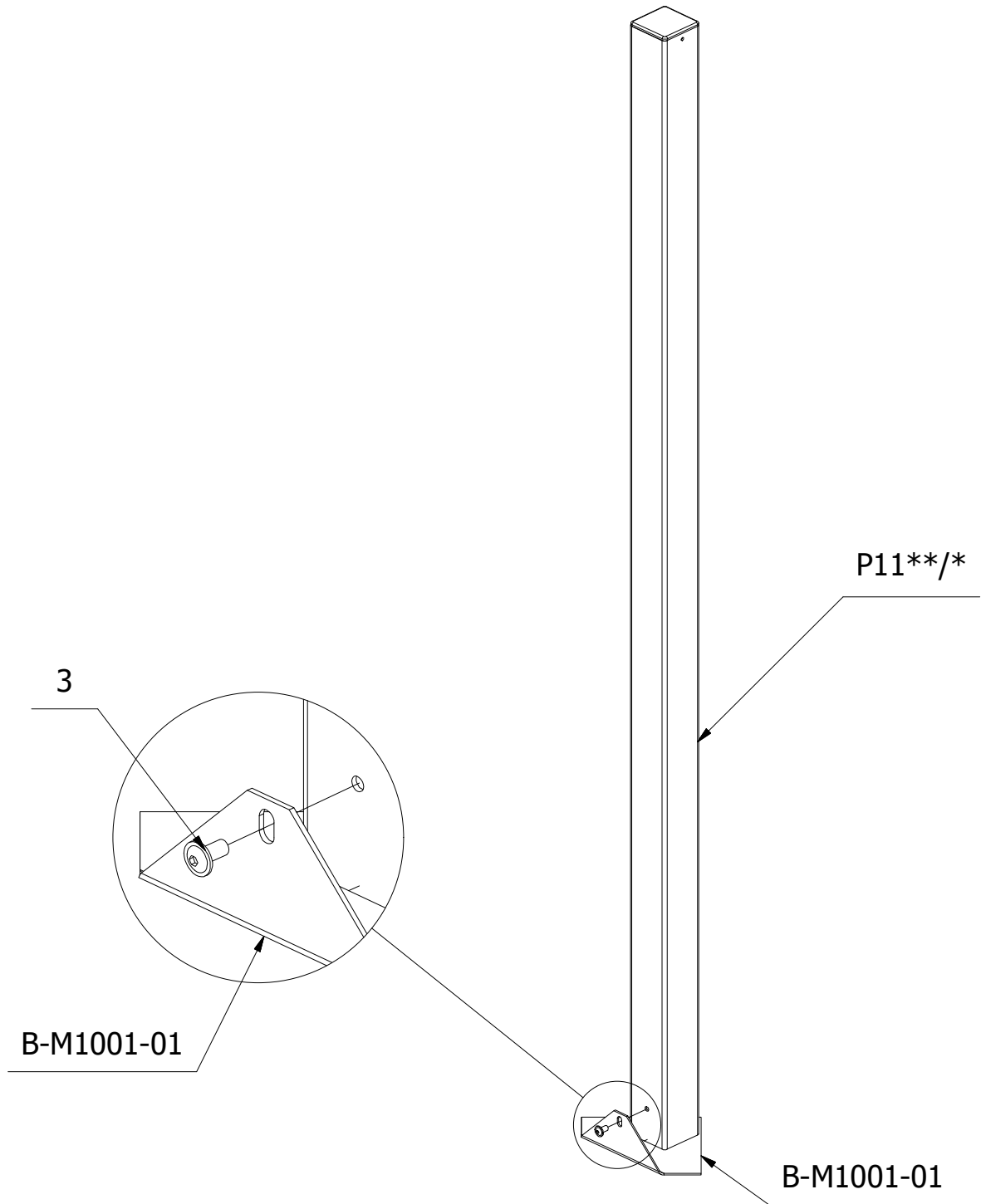

| Lp./ No | Nr kat. / Cat No | Ilość / Q |
|---------|--------------------|-----------|
| 1 | P11**/* | 1 |
| 2 | B-M1001-01 | 1 |
| 3 | ISO7380-2-M8x16-A2 | 1 |

M1101 / M1102 / M1103 / M1104 / M1115

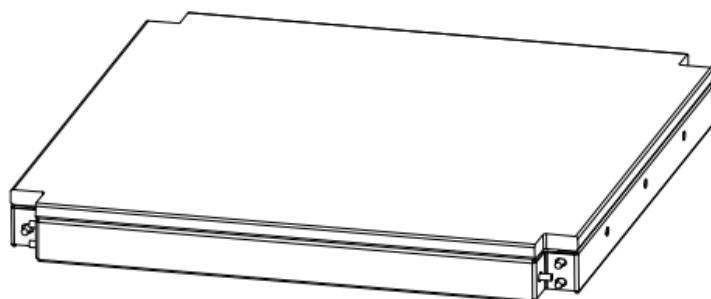

M1101 / M1102 / M1103 / M1104 / M1115

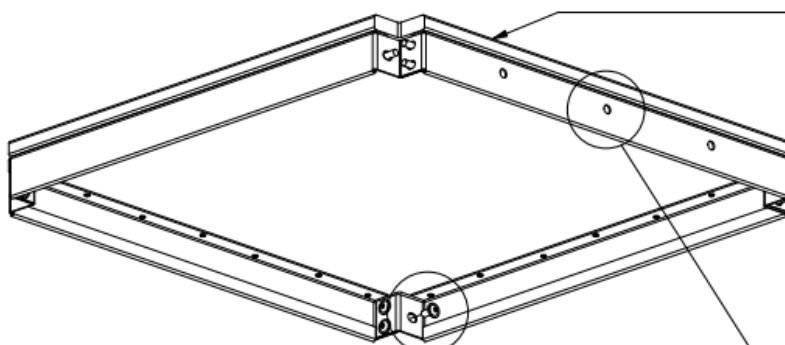

ISO7089-M8-A2

P0401-01

ISO7380-M10x20-A2

DIN985-M8-A2

P0401-02

x12

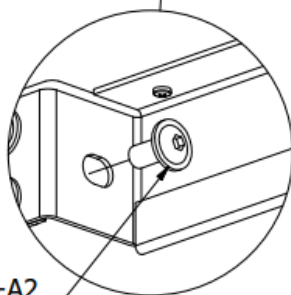

ISO7380-2-M8x16-A2

Cover unused holes.
Zakryć niewykorzystane otwory.

| Lp./ No. | Nr kat. / Cat No |
|----------|--------------------|
| 1 | P0401-01 |
| 2 | P0401-02 |
| 3 | ISO7380-2-M8x16-A2 |
| 4 | ISO7089-M8-A2 |
| 5 | DIN985-M8-A2 |

| Lp./ No. | Nr kat. / Cat No | Ilość / Quantity |
|----------|----------------------------------|------------------|
| 1 | M1101 / M1102 / M1103 / M1104 | 1 |
| 2 | ISO7380-2-M8x16-A2 | 12 |

M1111

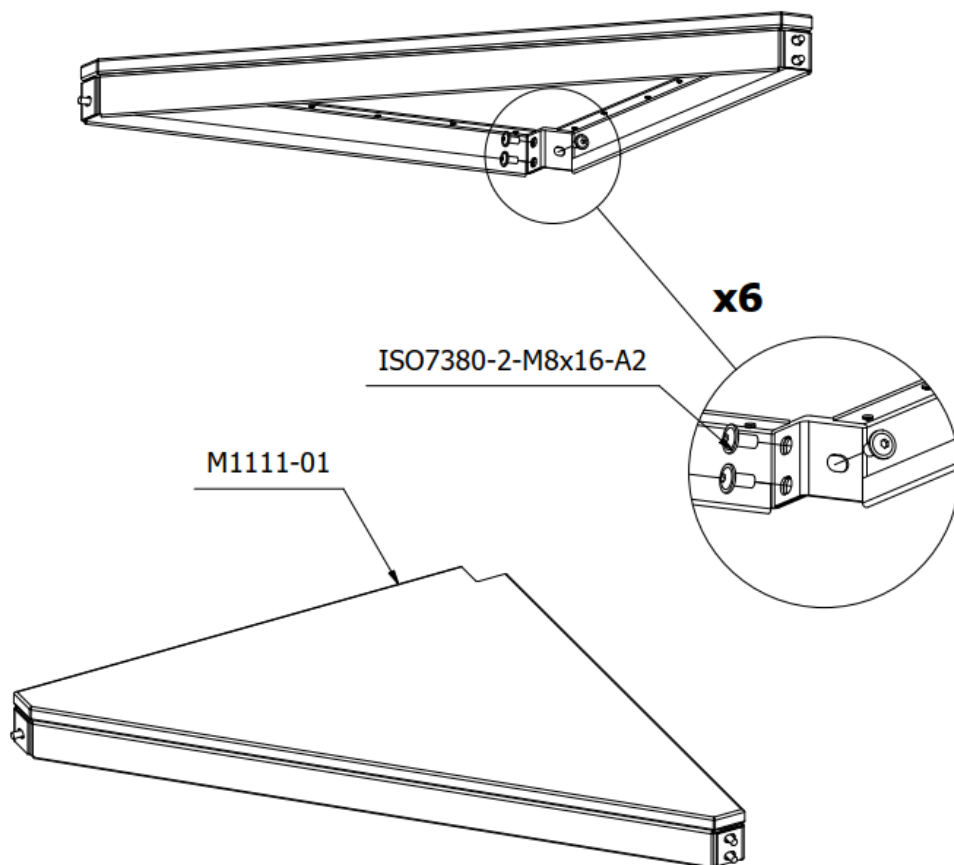

| Lp./ No. | Nr kat. / Cat No | Ilość / Quantity |
|----------|--------------------|------------------|
| 1 | M1111-01 | 1 |
| 2 | ISO7380-2-M8x16-A2 | 6 |

M1117

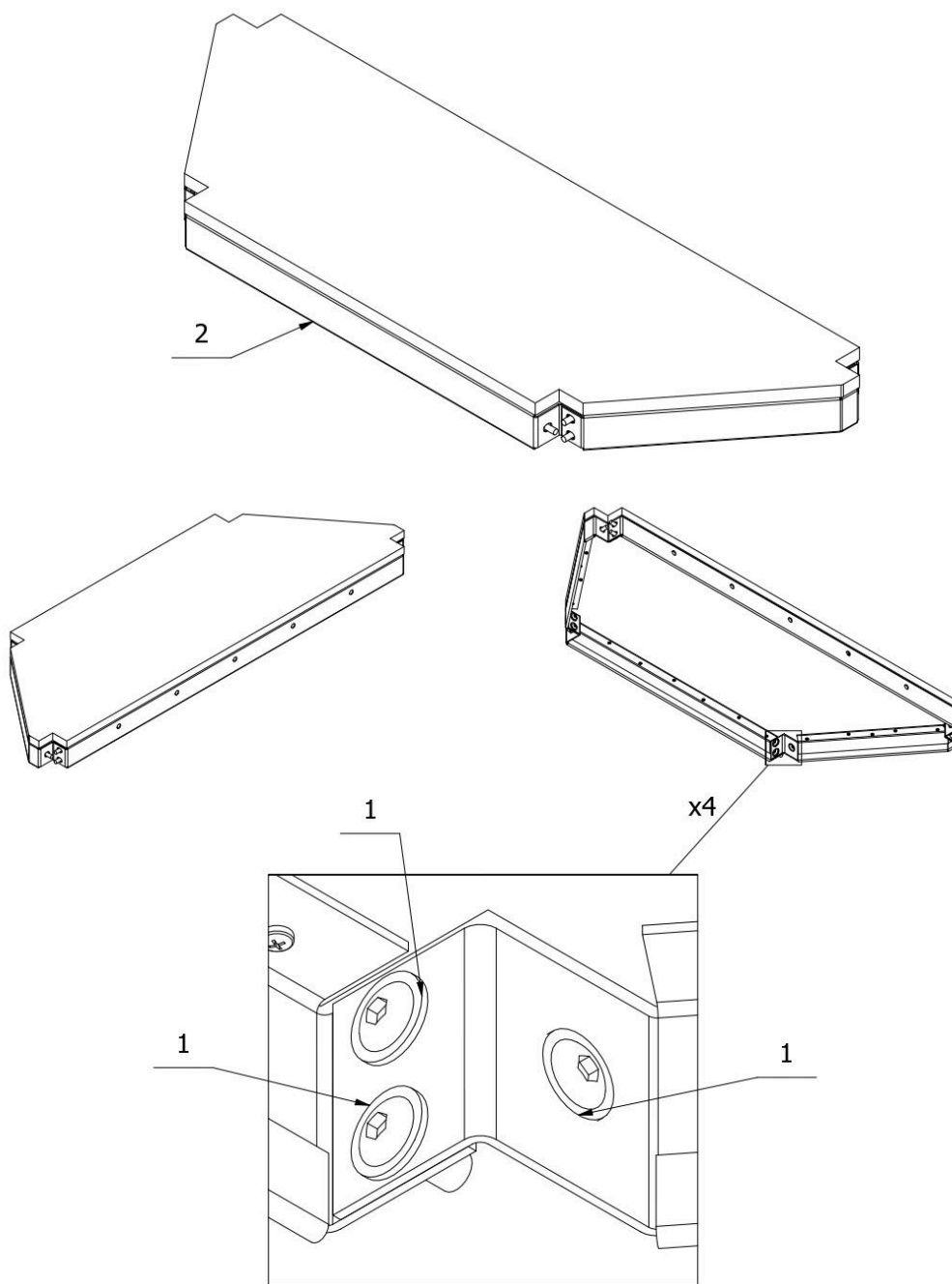

| Lp./ No. | Nr kat. / Cat No | Ilość / Quantity |
|----------|--------------------|------------------|
| 1 | ISO7380-2-M8x16-A2 | 12 |
| 2 | M1117_01 | 1 |

M1208

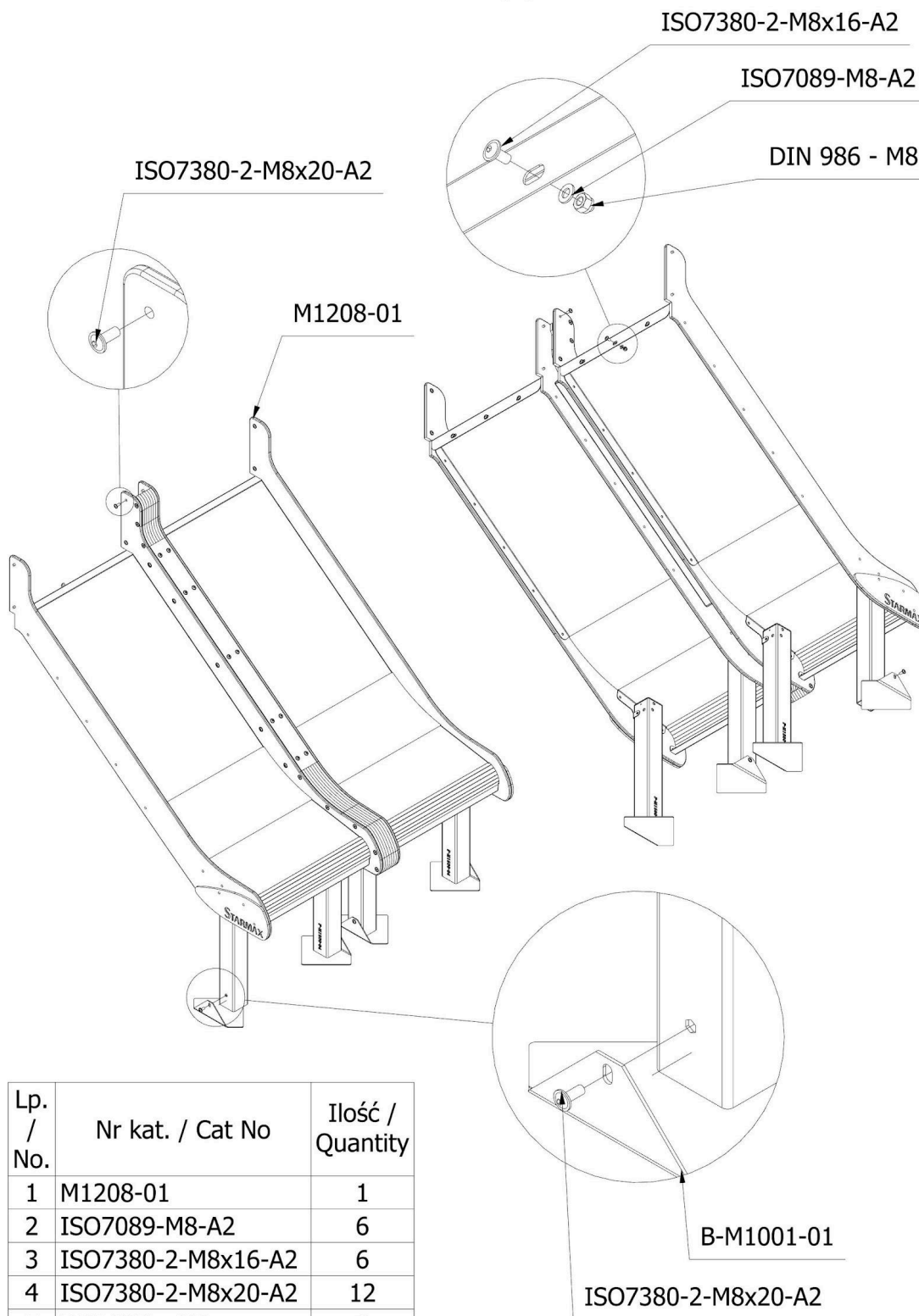

| Lp. / No. | Nr kat. / Cat No | Ilość / Quantity |
|-----------------|--------------------|---------------------|
| 1 | M1208-01 | 1 |
| 2 | ISO7089-M8-A2 | 6 |
| 3 | ISO7380-2-M8x16-A2 | 6 |
| 4 | ISO7380-2-M8x20-A2 | 12 |
| 5 | DIN 986 - M8 | 6 |
| 6 | B-M1001-01 | 4 |

M1209

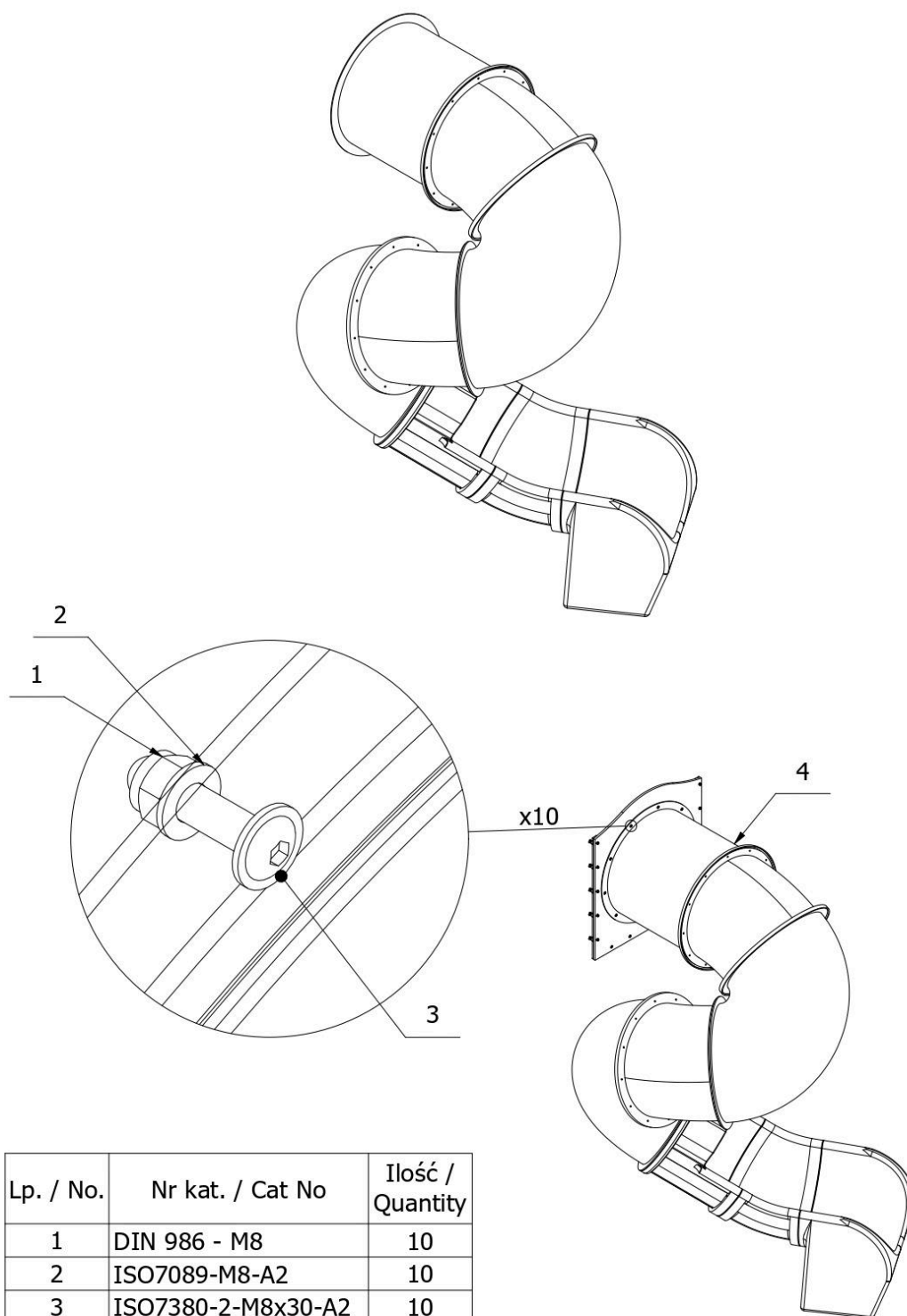

| Lp. / No. | Nr kat. / Cat No | Ilość / Quantity |
|-----------|--------------------|------------------|
| 1 | DIN 986 - M8 | 10 |
| 2 | ISO7089-M8-A2 | 10 |
| 3 | ISO7380-2-M8x30-A2 | 10 |
| 4 | M1209_01 | 1 |

M1301 / M1302

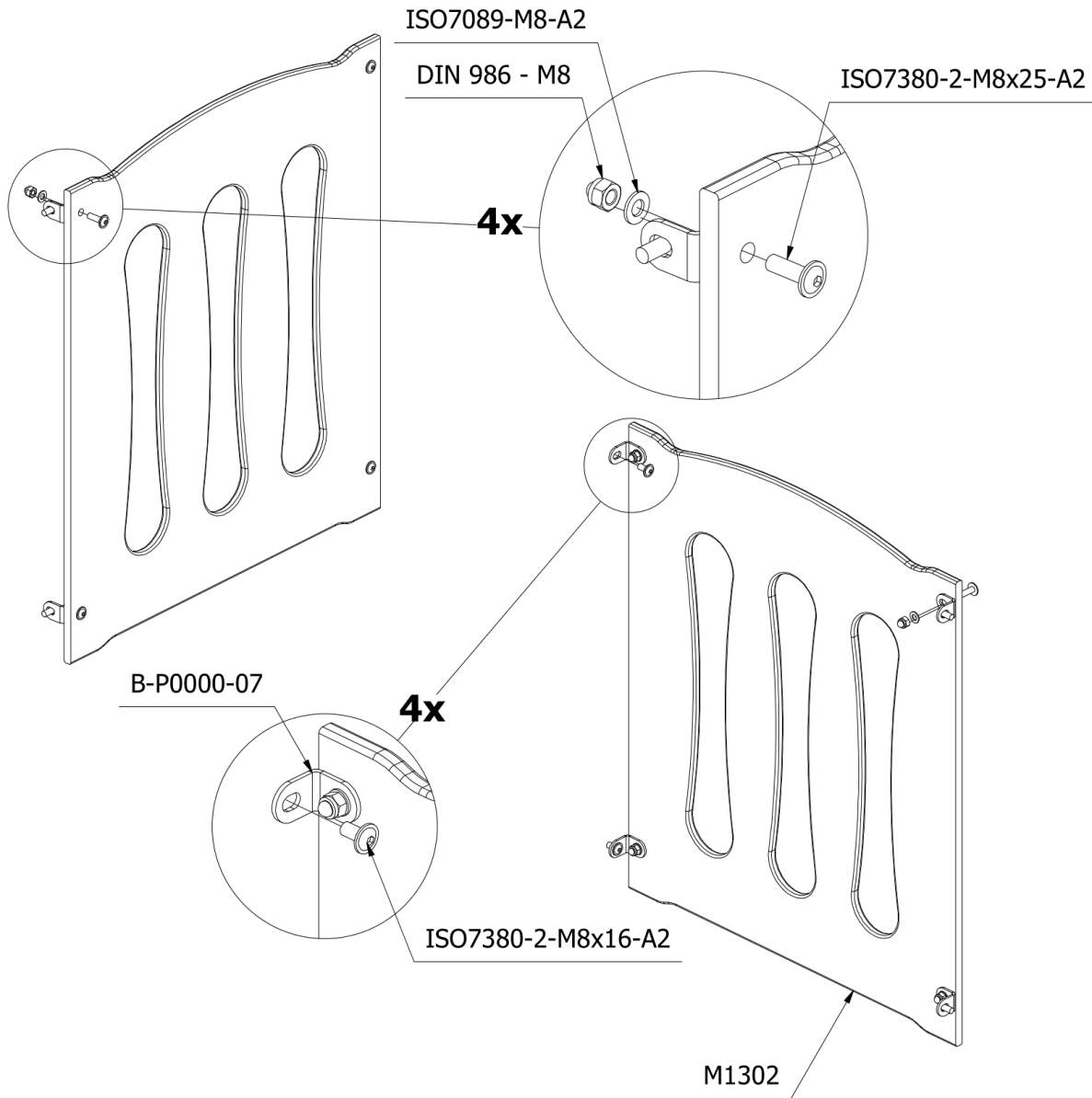

| Lp./ No. | Nr kat. / Cat No | Ilość / Quantity |
|----------|--------------------|------------------|
| 1 | M1301 / M1302 | 1 |
| 2 | B-P0000-07 | 4 |
| 3 | ISO7380-2-M8x25-A2 | 4 |
| 4 | ISO7089-M8-A2 | 4 |
| 5 | DIN 986 - M8 | 4 |
| 6 | ISO7380-2-M8x16-A2 | 4 |

M1304

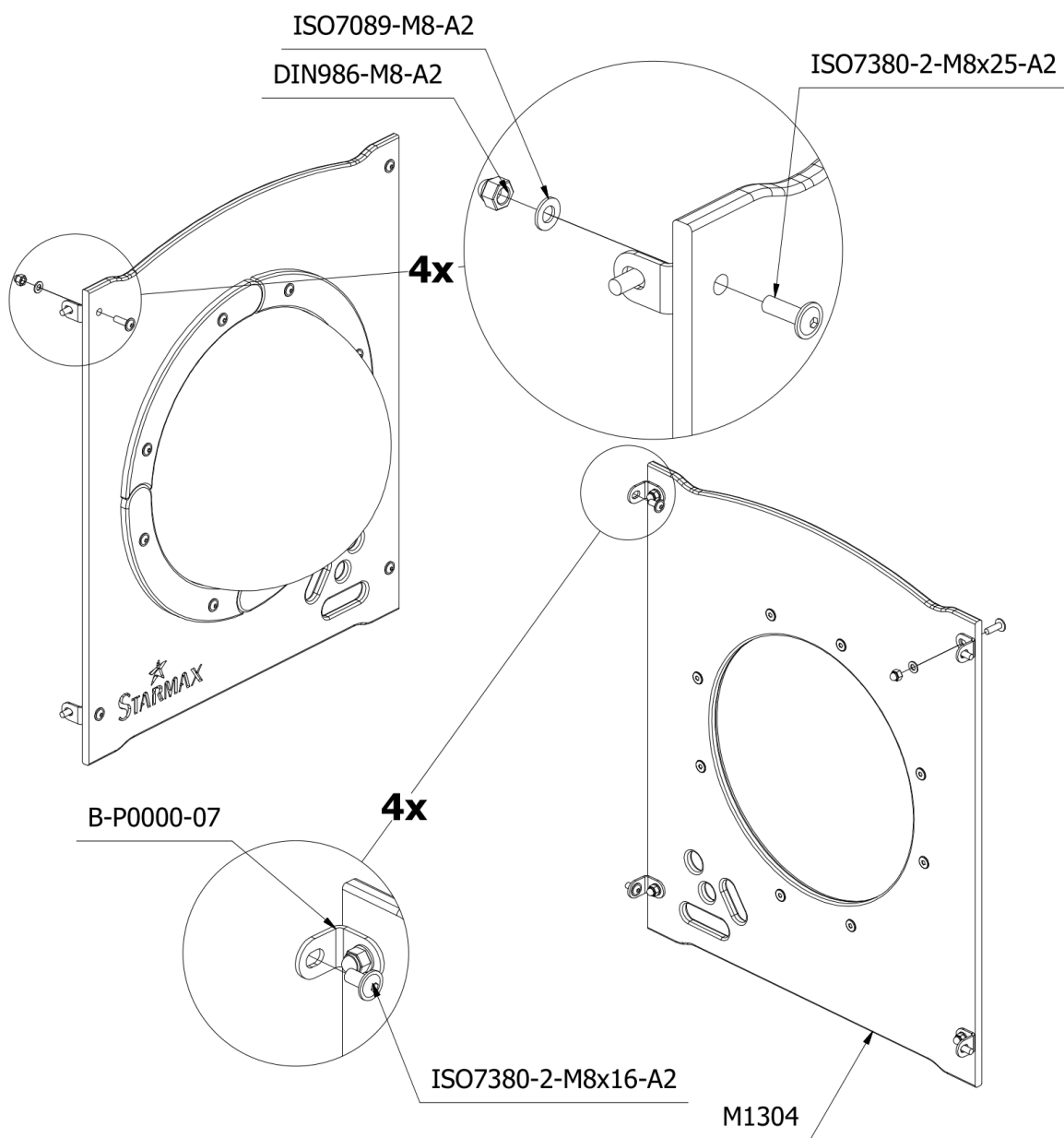

| Lp./ No. | Nr kat. / Cat No | Ilość / Quantity |
|----------|--------------------|------------------|
| 1 | M1304 | 1 |
| 2 | B-P0000-07 | 4 |
| 3 | ISO7380-2-M8x25-A2 | 4 |
| 4 | ISO7089-M8-A2 | 4 |
| 5 | DIN986-M8-A2 | 4 |
| 6 | ISO7380-2-M8x16-A2 | 4 |

M1334

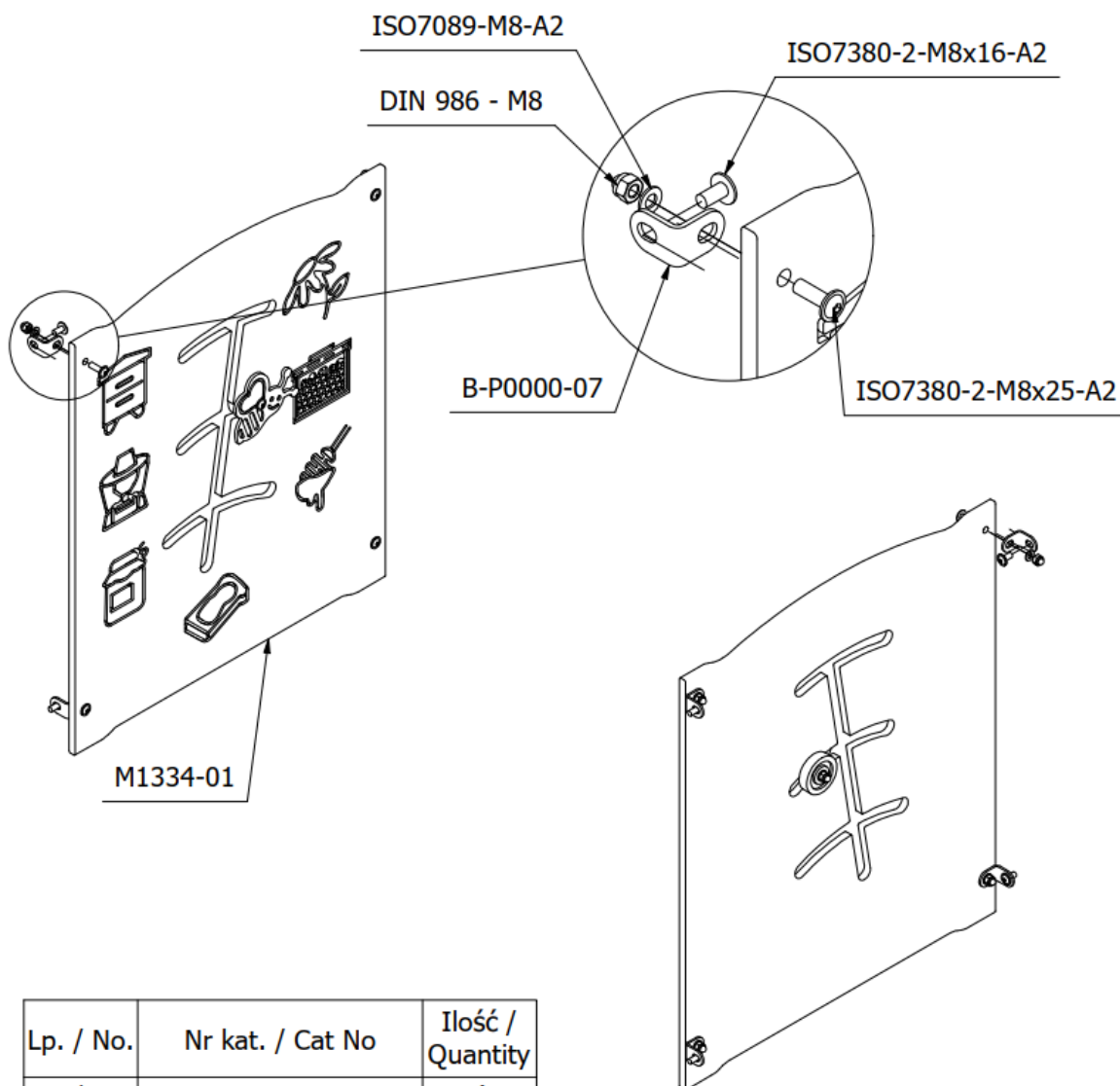

| Lp. / No. | Nr kat. / Cat No | Ilość / Quantity |
|-----------|--------------------|------------------|
| 1 | B-P0000-07 | 4 |
| 2 | ISO7380-2-M8x16-A2 | 4 |
| 3 | ISO7380-2-M8x25-A2 | 4 |
| 4 | ISO7089-M8-A2 | 4 |
| 5 | DIN 986 - M8 | 4 |
| 6 | M1334-01 | 1 |

M1338

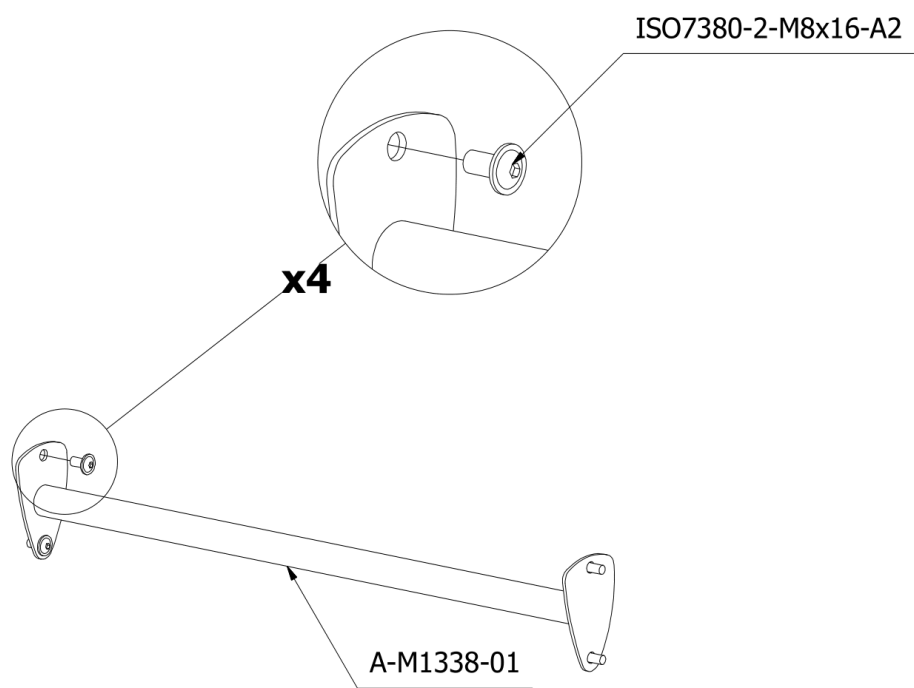

| Lp./ No. | Nr kat. / Cat No | Ilość / Quantity |
|----------|--------------------|------------------|
| 1 | A-M1338-01 | 1 |
| 2 | ISO7380-2-M8x16-A2 | 4 |

M1343 / M1374

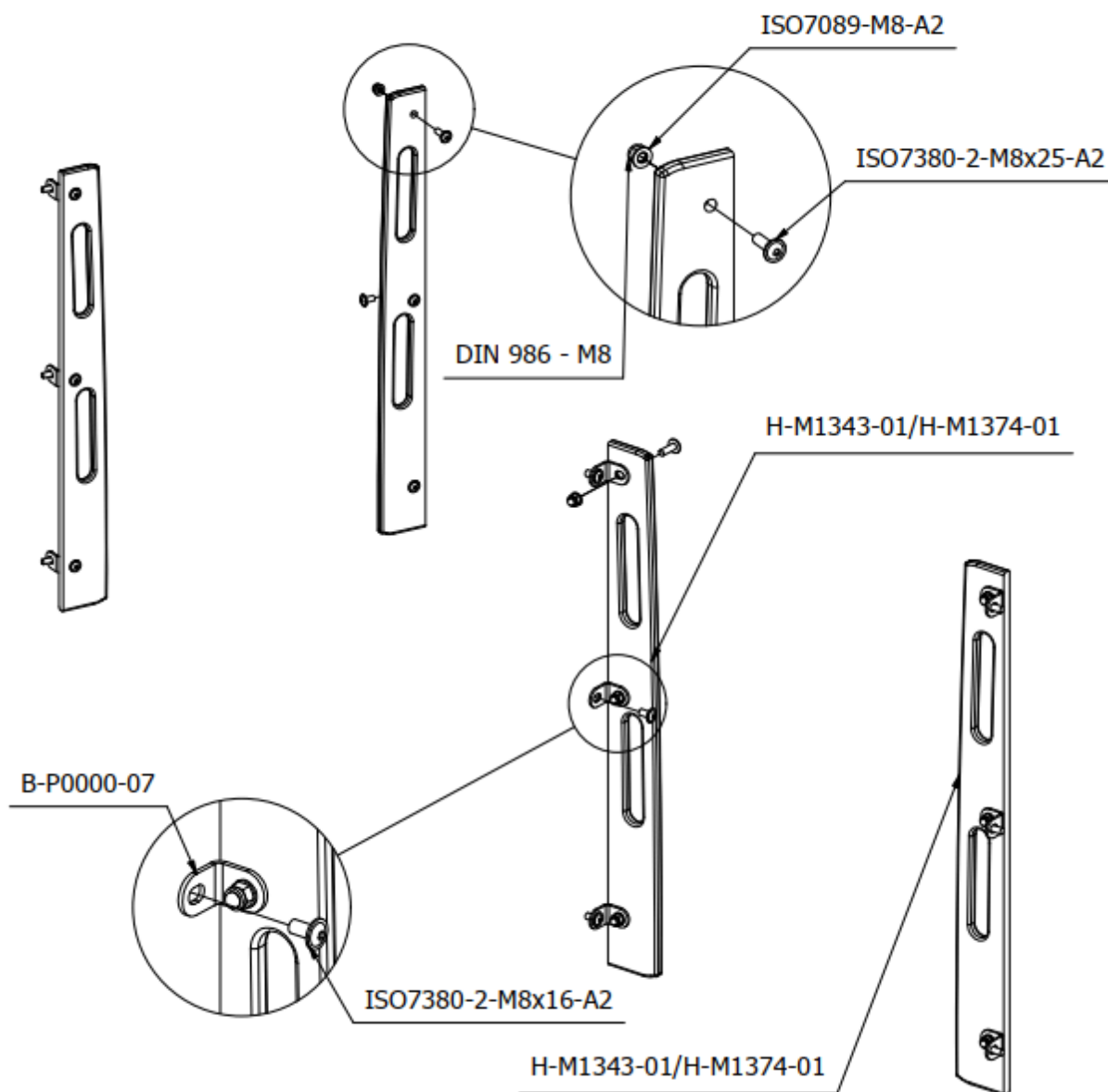

| Lp./ No. | Nr kat. / Cat No | Ilość / Quantity |
|----------|-----------------------|------------------|
| 1 | H-M1343-01/H-M1374-01 | 2 |
| 2 | B-P0000-07 | 6 |
| 5 | ISO7380-2-M8x25-A2 | 6 |
| 7 | ISO7380-2-M8x16-A2 | 6 |
| 8 | ISO7089-M8-A2 | 6 |
| 9 | DIN 986 - M8 | 6 |

H-M1343-01



H-M1374-01

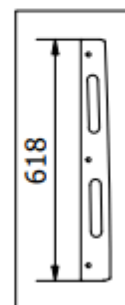

M1381

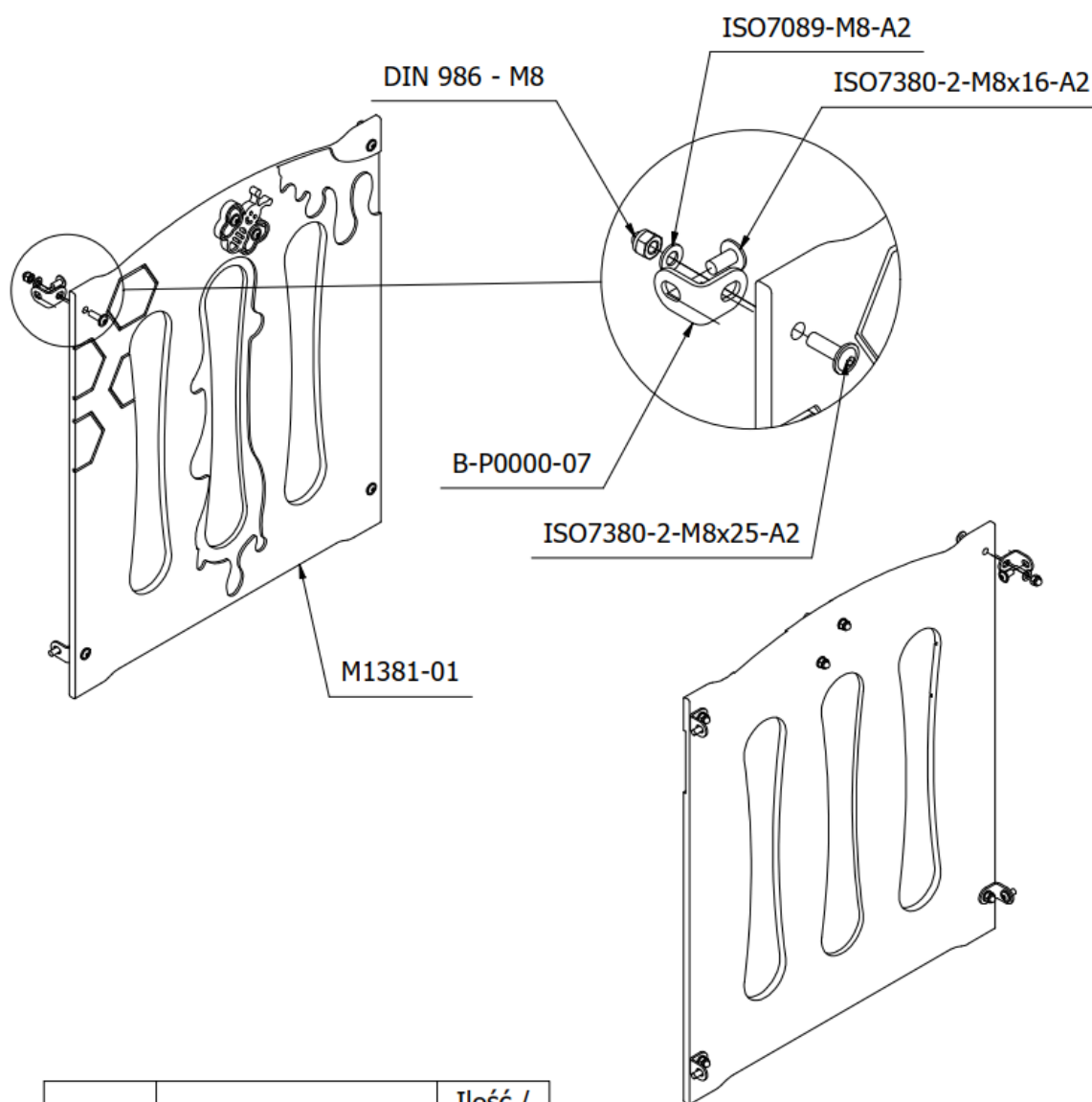

| Lp. / No. | Nr kat. / Cat No | Ilość / Quantity |
|-----------|--------------------|------------------|
| 1 | B-P0000-07 | 4 |
| 2 | ISO7380-2-M8x25-A2 | 4 |
| 3 | ISO7089-M8-A2 | 4 |
| 4 | DIN 986 - M8 | 4 |
| 5 | ISO7380-2-M8x16-A2 | 4 |
| 6 | M1381-01 | 1 |

M13101 / M13101_OL

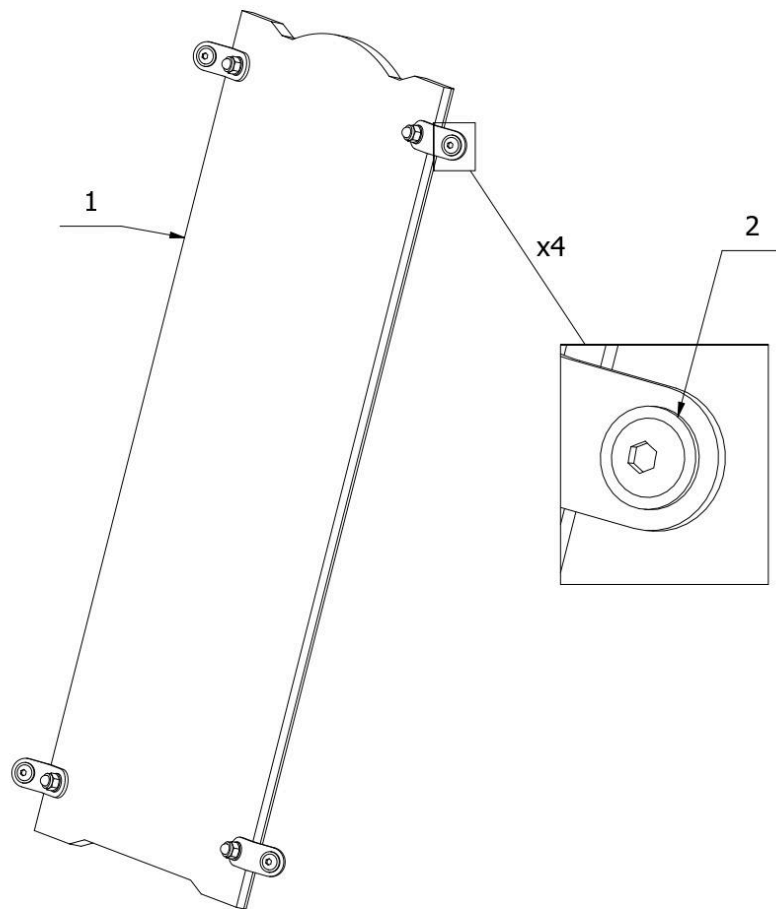

| Lp. / No. | Nr kat. / Cat No | Ilość / Quantity |
|-----------|--------------------------|------------------|
| 1 | M13101_01 / M13101_01_OL | 1 |
| 2 | ISO7380-2-M8x16-A2 | 4 |

M13102

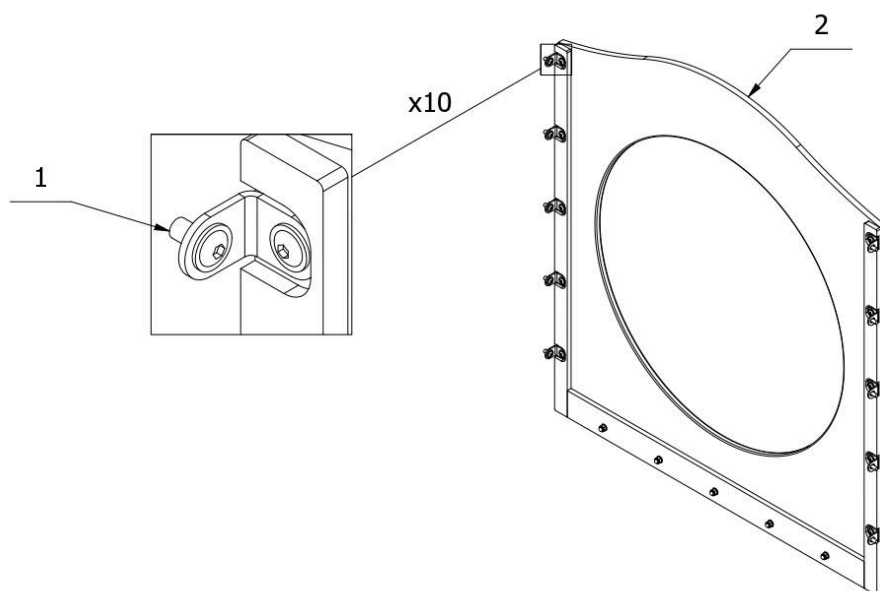
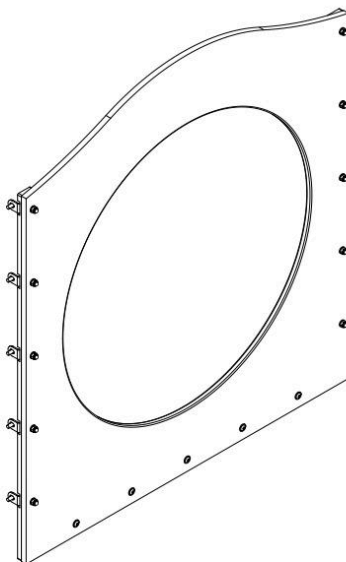

| Lp. / No. | Nr kat. / Cat No | Ilość / Quantity |
|-----------|--------------------|------------------|
| 1 | ISO7380-2-M8x16-A2 | 10 |
| 2 | M13102_01 | 1 |

M1418

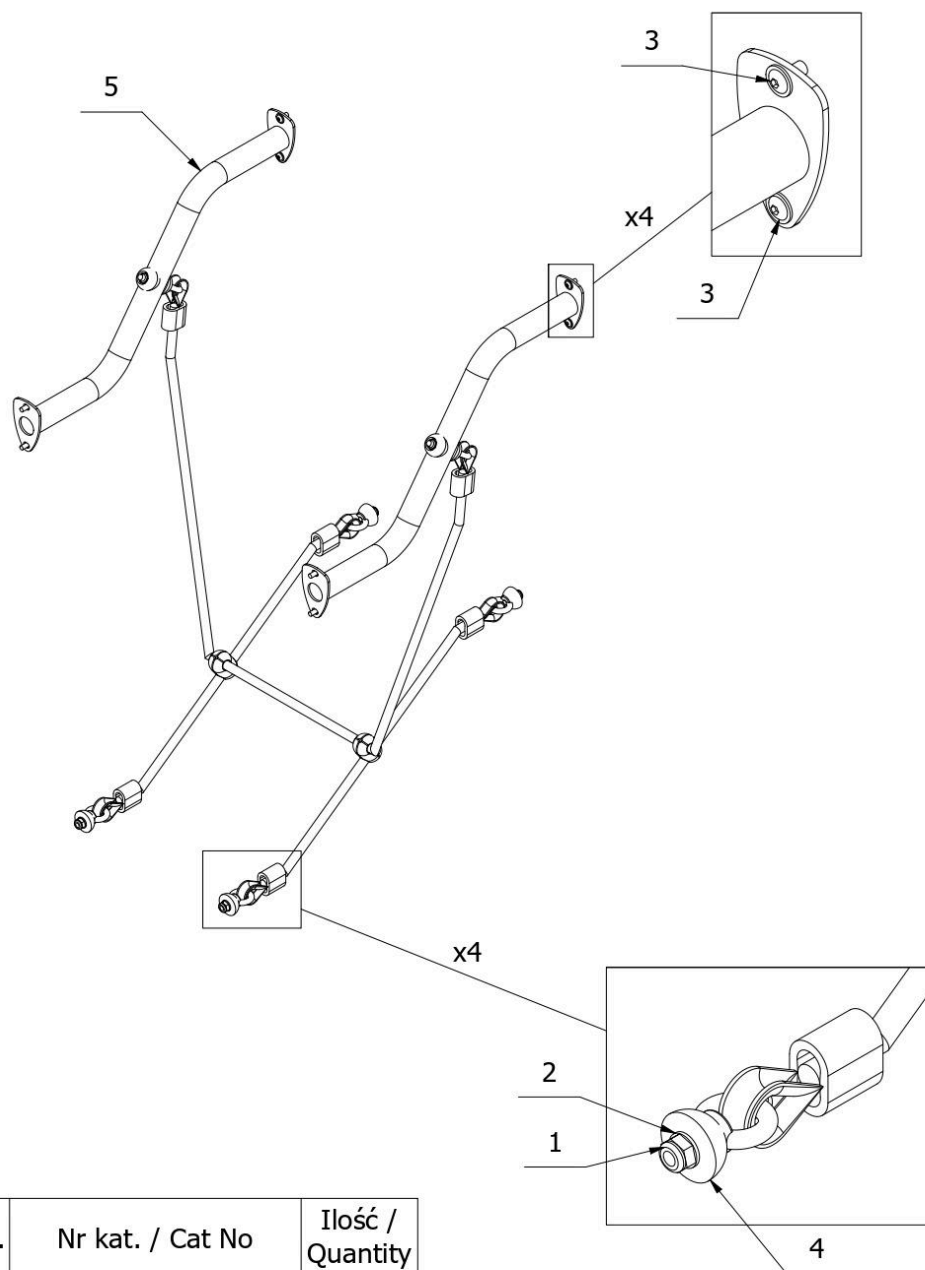

| Lp. / No. | Nr kat. / Cat No | Ilość / Quantity |
|-----------|--------------------|------------------|
| 1 | DIN985-M10-A2 | 4 |
| 2 | ISO7089-M10-A2 | 4 |
| 3 | ISO7380-2-M8x16-A2 | 8 |
| 4 | K02 | 4 |
| 5 | M1418_01 | 1 |

M1427

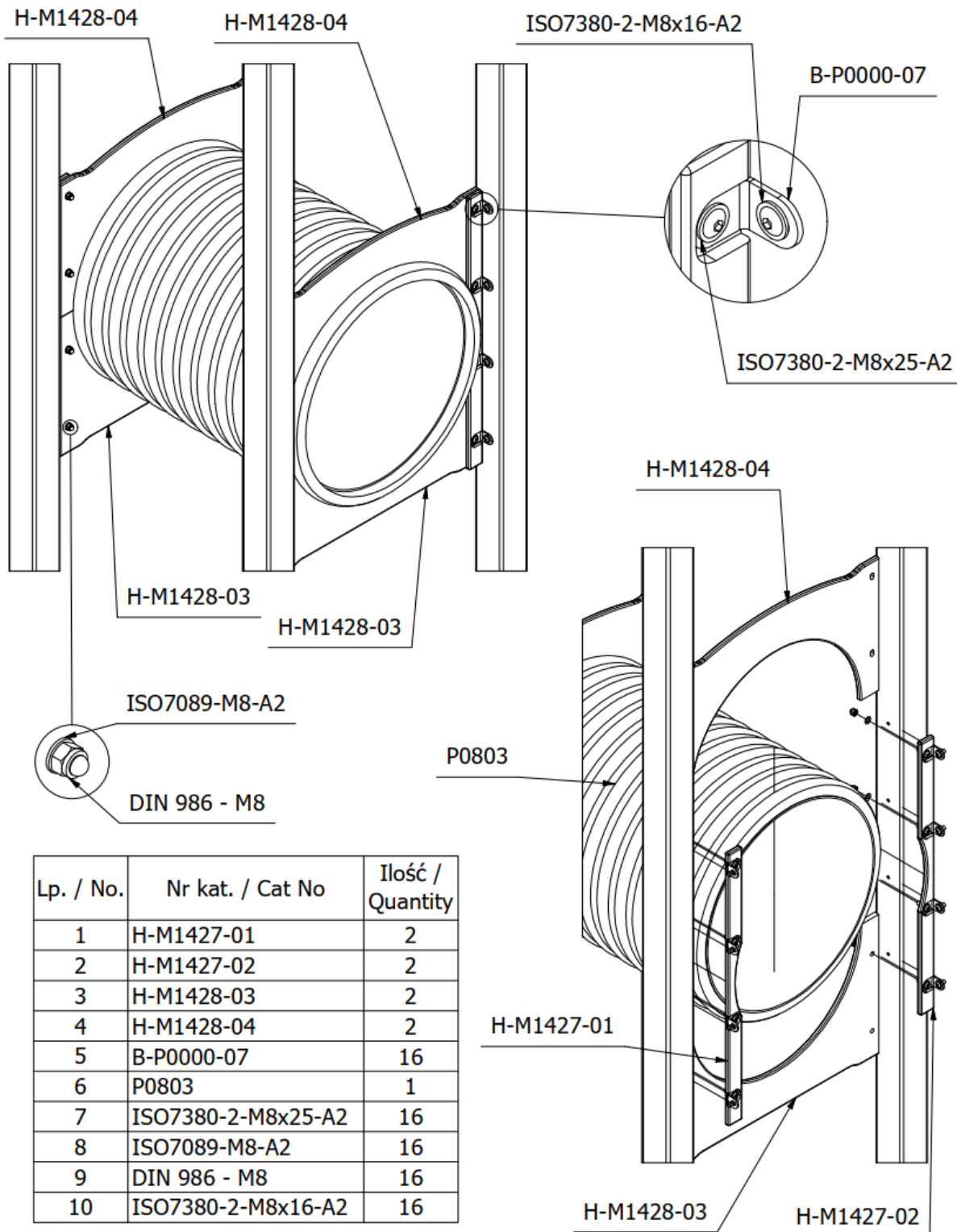

| Lp. / No. | Nr kat. / Cat No | Ilość / Quantity |
|-----------|--------------------|------------------|
| 1 | H-M1427-01 | 2 |
| 2 | H-M1427-02 | 2 |
| 3 | H-M1428-03 | 2 |
| 4 | H-M1428-04 | 2 |
| 5 | B-P0000-07 | 16 |
| 6 | P0803 | 1 |
| 7 | ISO7380-2-M8x25-A2 | 16 |
| 8 | ISO7089-M8-A2 | 16 |
| 9 | DIN 986 - M8 | 16 |
| 10 | ISO7380-2-M8x16-A2 | 16 |

M1514

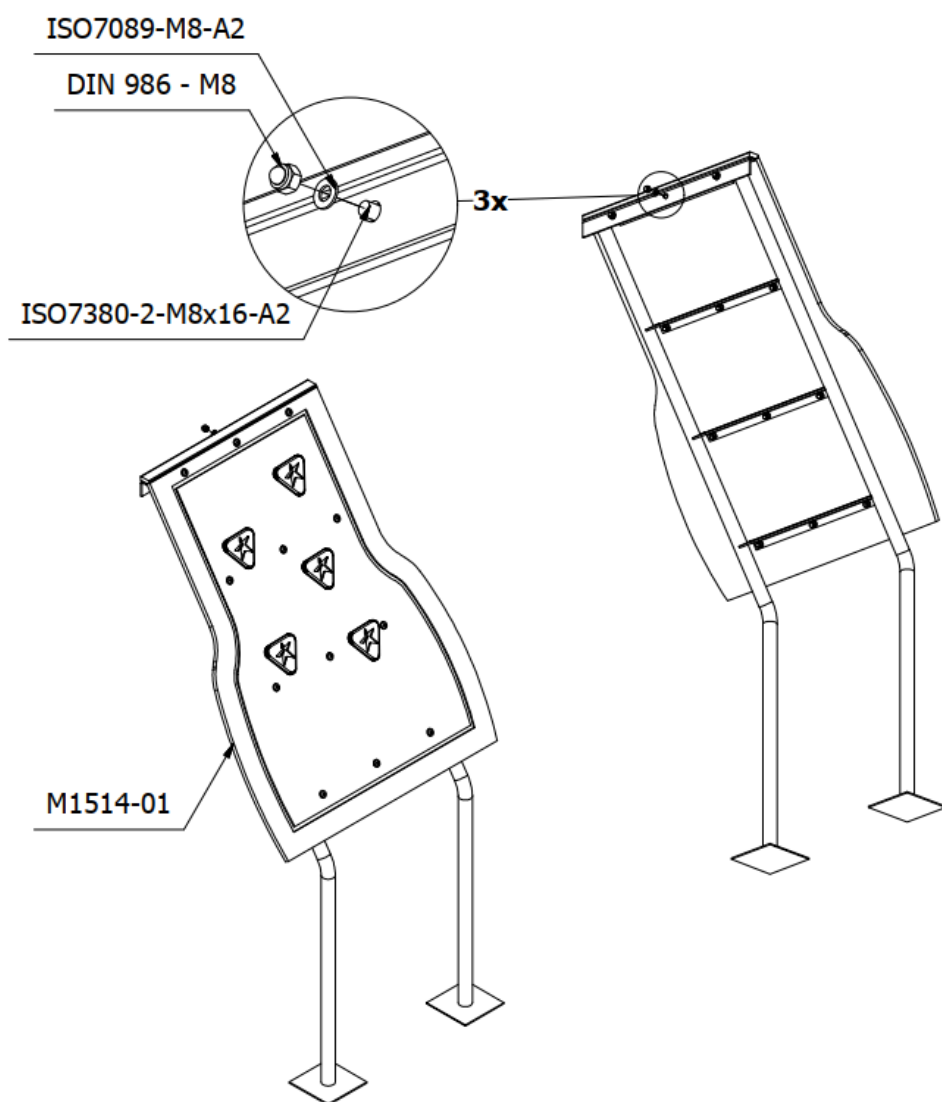

| Lp./ No. | Nr kat. / Cat No | Ilość / Quantity |
|----------|--------------------|------------------|
| 1 | M1514-01 | 1 |
| 2 | ISO7089-M8-A2 | 3 |
| 3 | DIN 986 - M8 | 3 |
| 4 | ISO7380-2-M8x16-A2 | 3 |

M1545/M1546/M1547/M1548

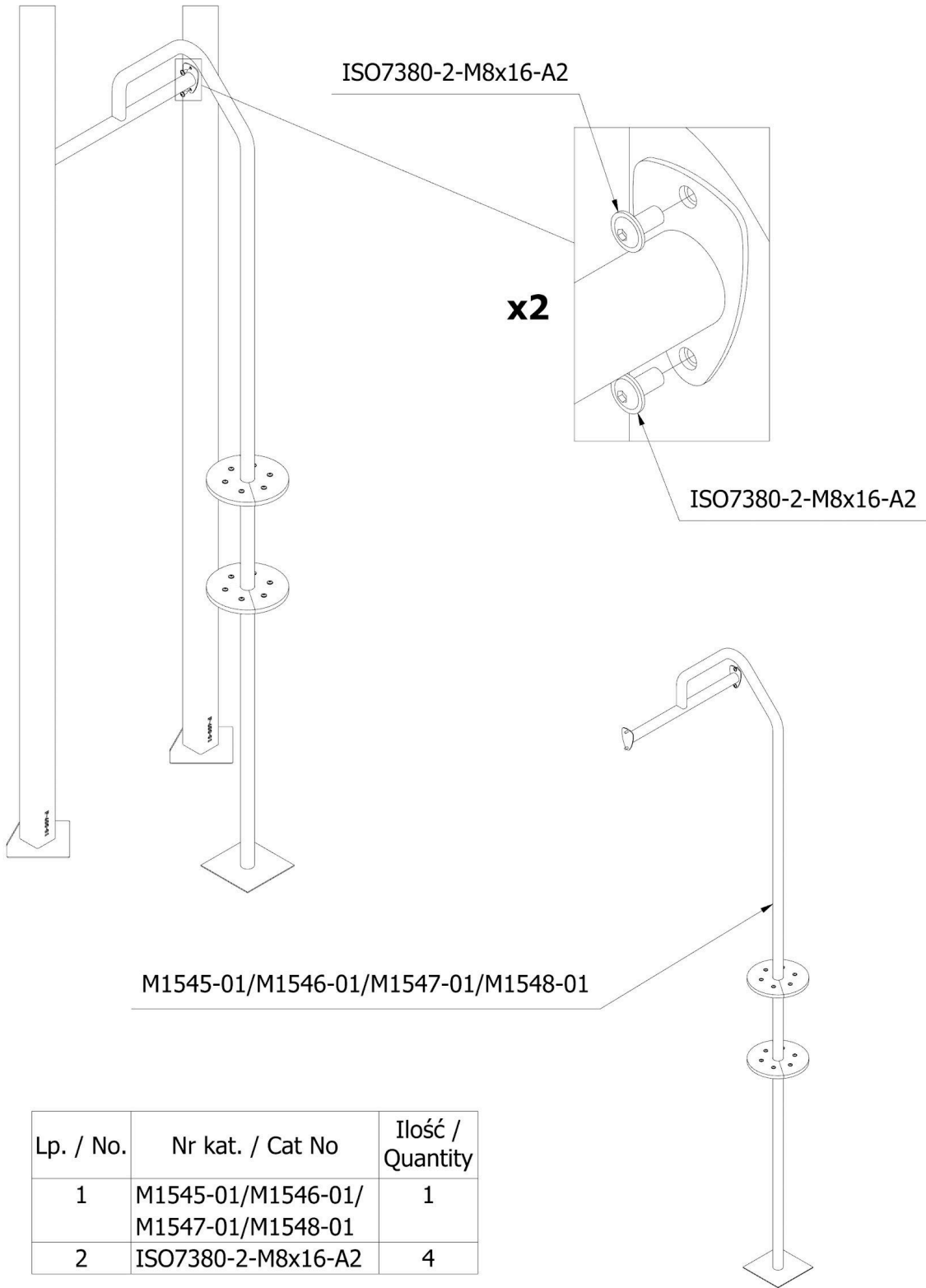

| Lp. / No. | Nr kat. / Cat No | Ilość / Quantity |
|-----------|---|------------------|
| 1 | M1545-01/M1546-01/ M1547-01/M1548-01 | 1 |
| 2 | ISO7380-2-M8x16-A2 | 4 |

M1601

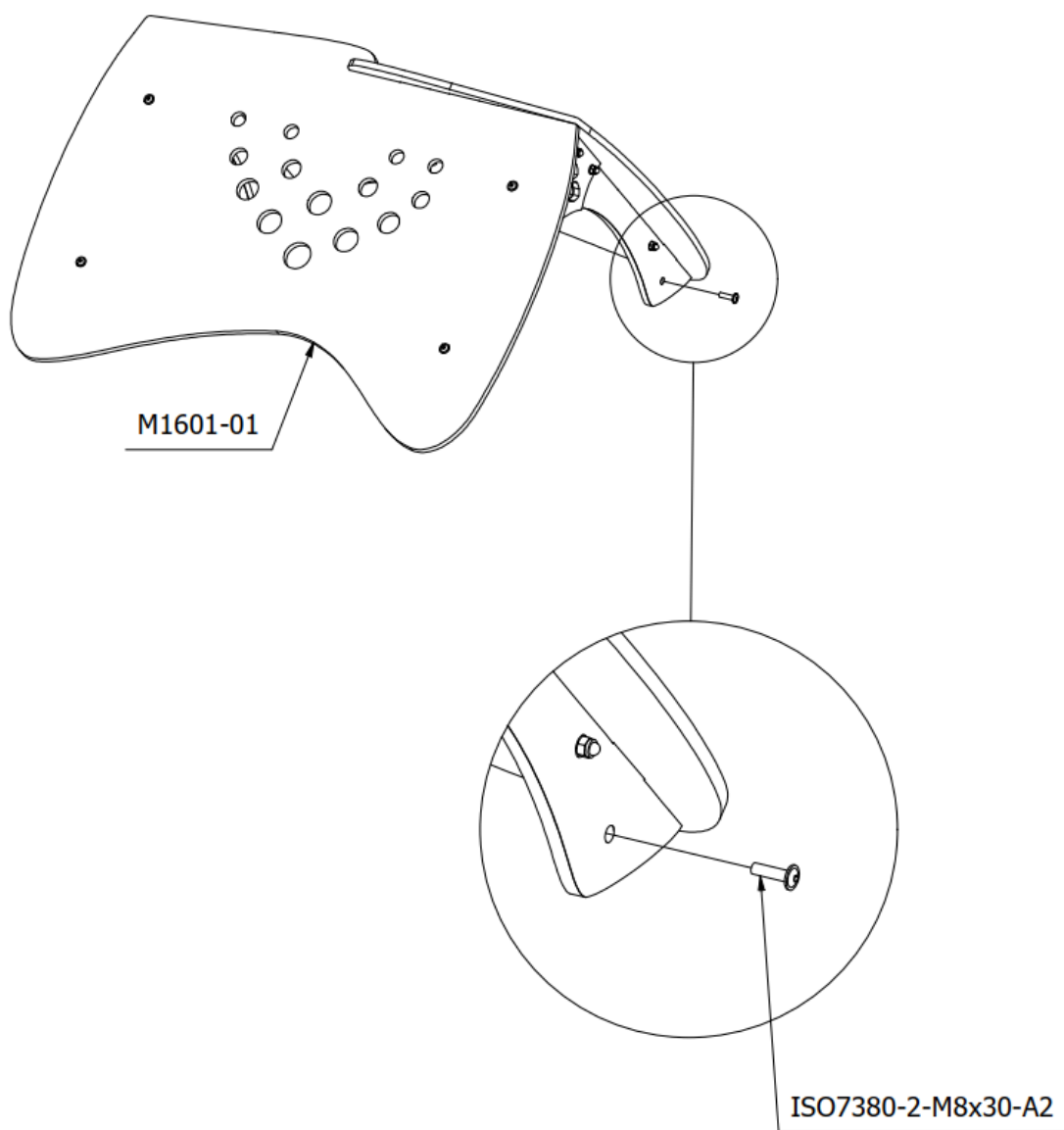

| Lp./ No. | Nr kat. / Cat No | Ilość / Quantity |
|----------|--------------------|------------------|
| 1 | M1601-01 | 1 |
| 2 | ISO7380-2-M8x30-A2 | 4 |

M1710

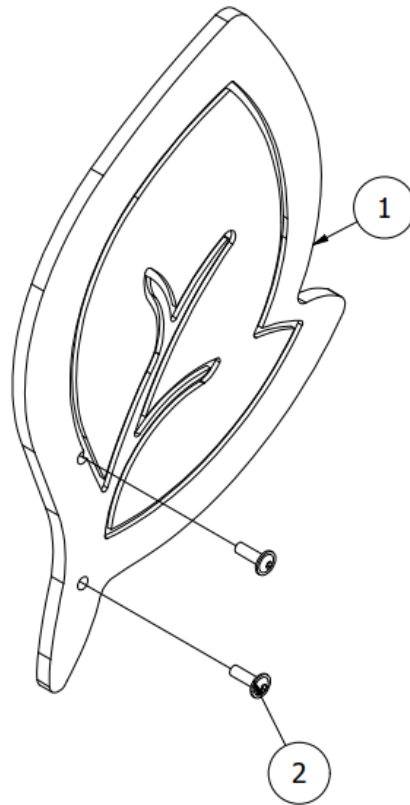

| Lp. | Nr kat. | Ilość |
|-----|--------------------|-------|
| 1 | H-M1710-01 | 1 |
| 2 | ISO7380-2-M8x25-A2 | 2 |

M1711/M1711-OL

H-P1500-22/H-P1500-22-OL

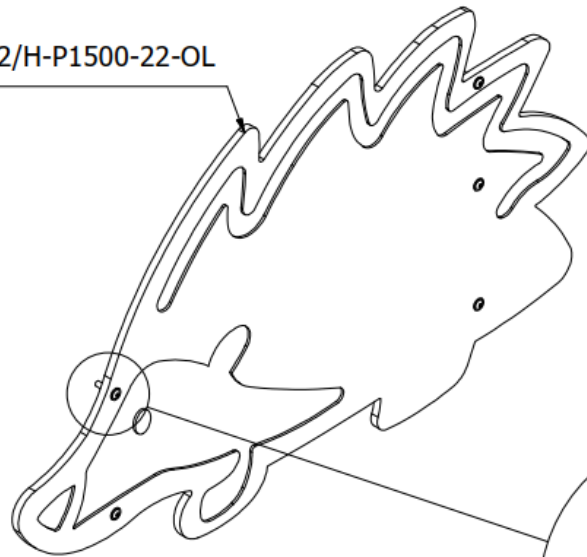

ISO7380-2-M8x35-A2

x5

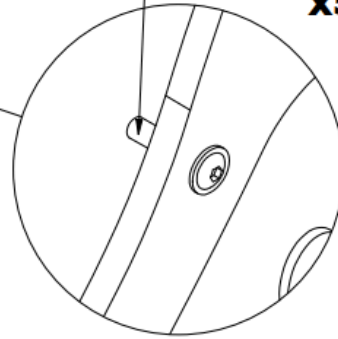

H-P1500-22-OL

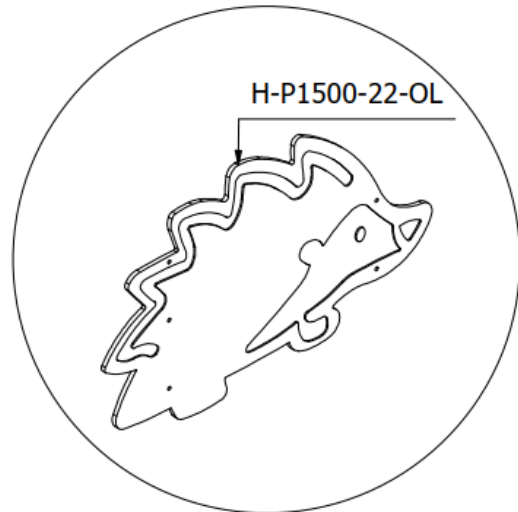

| Lp. / No. | Nr kat. / Cat No | Ilość / Quantity |
|-----------|--------------------------|------------------|
| 1 | H-P1500-22/H-P1500-22-OL | 1 |
| 2 | ISO7380-2-M8x35-A2 | 5 |